

si riserva di apportare senza alcun preavviso qualsiasi modifica alle caratteristiche tecniche indicate nel presente catalogo.

reserves the right to modify the technical data mentioned into this catalogue without notice.



- Anelli fermacarico
- Ganci telone e tendifune
- Supporti asta centina
- Avvolgimento tourillon
- Supporto tubo centina
- Supporti per fissaggio chassis

- *Lashing ring*
- *Rope guide hooks*
- *Steel pockets*
- *Drop - forged steel link pin*
- *Roof rubber brackets*
- *Body mounted brackets*

9

Anello fermacarico
Lashing ring
Anneau de fixation
Zurringe

Art.45020304 - Inox / Stainless steel / Nirosta

Art.45020314 - Zincato / Galvanized / Zingué / Verzinkt
0,200 kg

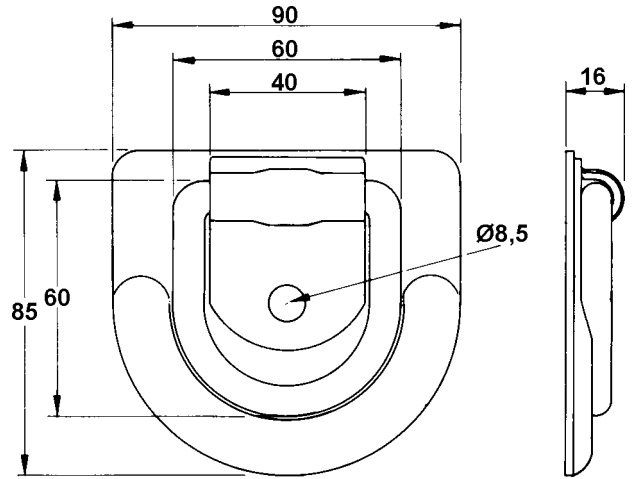

Carico di rottura
Breacking test load
2000 kg

Anello fermacarico incassato
Recessed lashing ring
Anneau de fixation encastrer
Zurringe

Art.45020303 - Inox / Stainless steel / Nirosta

Art.45020313 - Zincato / Galvanized / Zingué / Verzinkt
0,200 kg

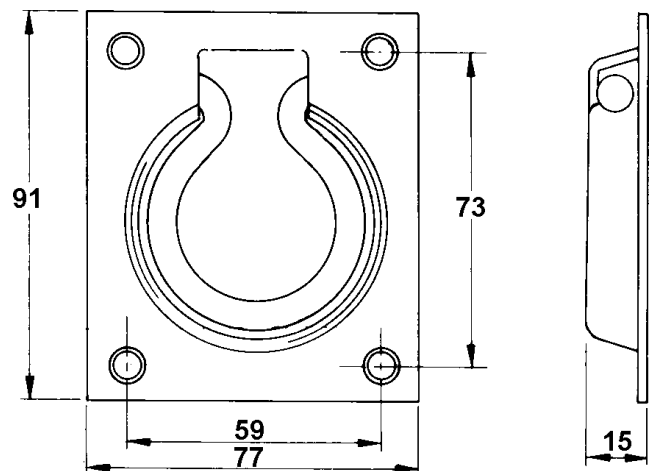

Carico di rottura
Breacking test load
370 kg

Anello fermacarico incassato con molla
Recessed lashing ring with spring
Anneau de fixation avec ressort
Zurringe mti feder

Art.45095210 - Zincato a caldo / *Hot Galvanized* / Zingué a chaud / *Feuer Verzinkt*

Art.45095200 - Inox / *Stainless steel* / Nirosta

Art.45095110 - Zincato / *Galvanized* / Zingué / *Verzinkt*

0,380 kg



Carico di rottura
Breaking test load
2000 kg

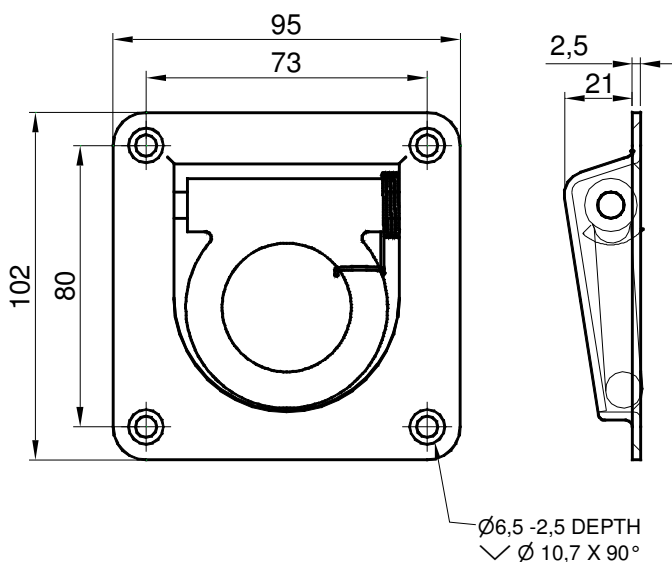

Anello fermacarico zincato a caldo con molla
Hot galvanized lashing ring with spring
Anneau de fixation Zingué a chaud avec ressort
Zurringe Feuer Verzinkt mti feder

Art.45095410 - 0,385 kg



Carico di rottura
Breaking test load
2000 kg

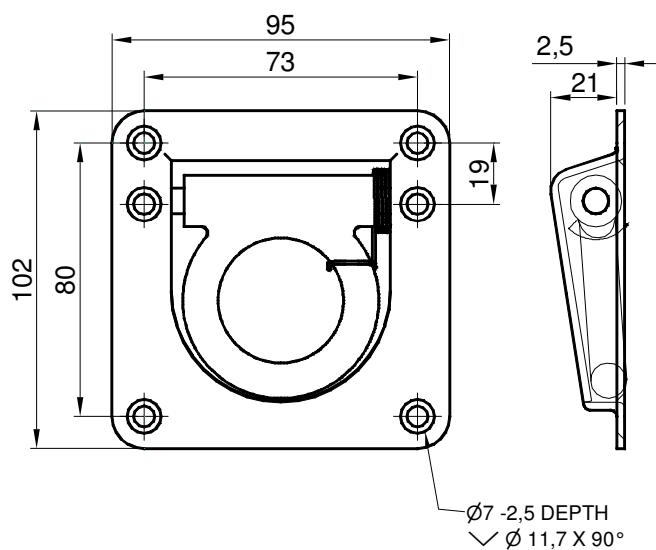

Anello fermacarico incassato con molla

Recessed lashing ring with spring

Anneau de fixation encastrer

Zurringe mit feder

Art.45093210 - Inox / *Stainless steel* / Nirosta

Art.45093110 - Zincato / *Galvanized* / Zingué / Verzinkt

0,440 kg

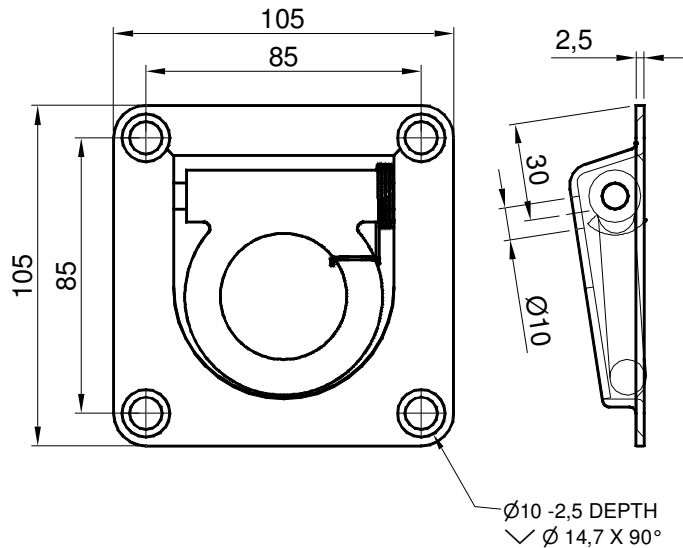

Carico di rottura
Breaking test load
2000 kg

Anello fermacarico zincato incassato ribaltabile

Galvanized recessed lashing ring overturning

Anneau de fixation zingué encastrer

Zurringe Verzinkt

Art.45092110 - **0,600 kg**

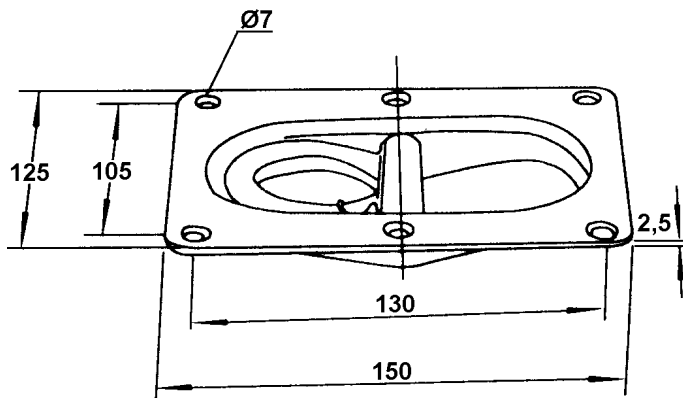

Carico di rottura
Breaking test load
2000 kg

Anello fermacarico incassato zincato
Galvanized Recessed lashing ring
Anneau de fixation encastrer zinguè
Anschraub Zurmulde verzinkt
Art.45095310 - 0,460 kg

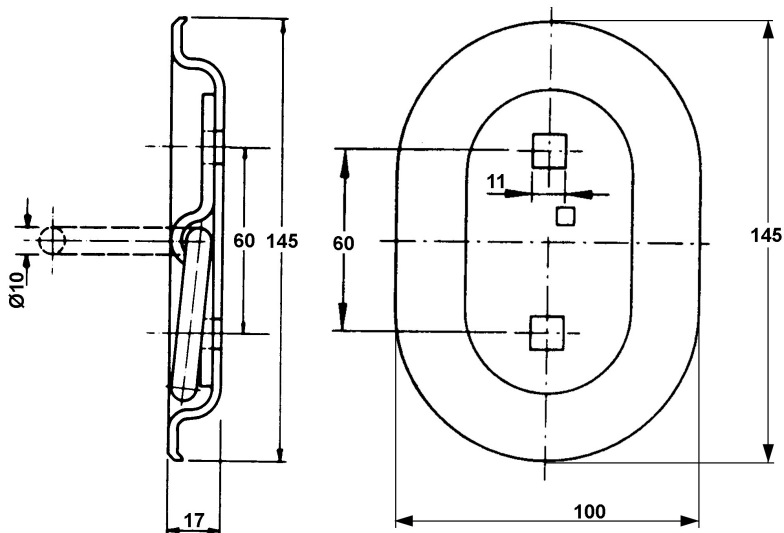

Carico di rottura
Breaking test load
800 kg

Anello fermacarico
Lashing ring
Anneau de fixation
Zincato - Galvanized - Verzinkt
Art.45095311 - 0,170 kg
Inox - Stainless steel - Nirosta
Art.45095320 - 0,170 kg

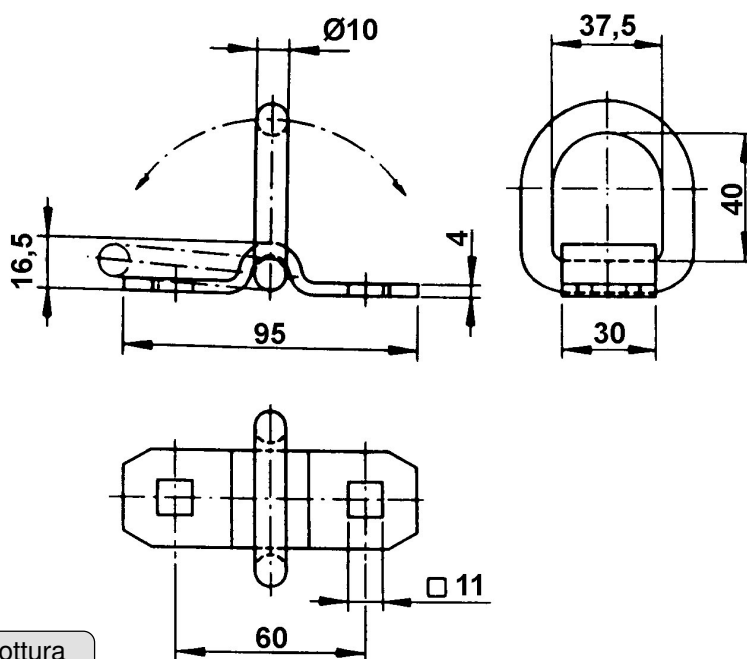

Carico di rottura
Breaking test load
800 kg

Anello fermacarico incassato zincato
Galvanized Recessed lashing ring
Anneau de fixation encastrer zinguè
Anschraub Zurmulde verzinkt
Art.45095510 - 0,380 kg

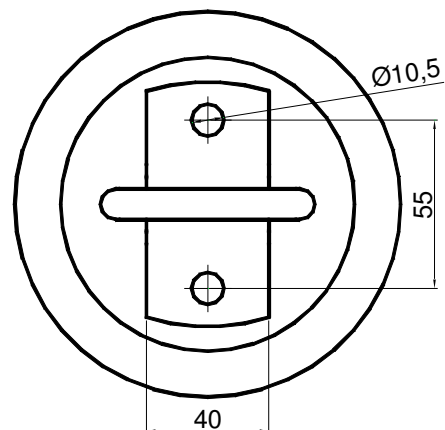
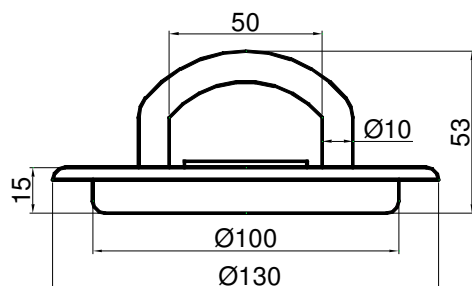

Carico di rottura
Breaking test load
800 kg

Anello fermacarico incassato in alluminio
Aluminium Recessed lashing ring
Anneau de fixation encastrer Alluminium
Aluminium zurringe
Art.45090110 - 0,480 kg

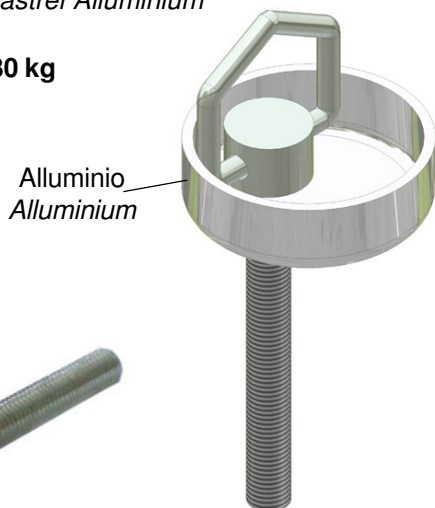

Alluminio
Aluminium

Solo perno
Only pin
Art.45090111



Solo incasso
Only recessed
Art.45090112

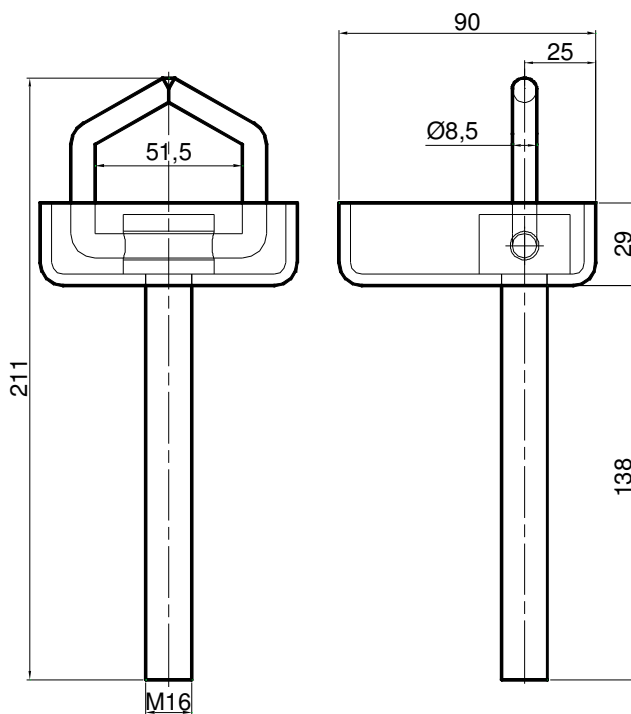

Carico di rottura
Breaking test load
1900 kg

Anello fermacarico incassato forgiato
Forged Recessed lashing ring
Anneau de fixation encastrer brut
Einschweiß - zurringe roh

Art.45098110 - 0,900 kg

Anello fermacarico incassato forgiato e zincato
Galvanized forged Recessed lashing ring
Anneau de fixation encastrer zinguè
Anschraub Zurrmulde verzinkt

Art.45098210 - 0,900 kg

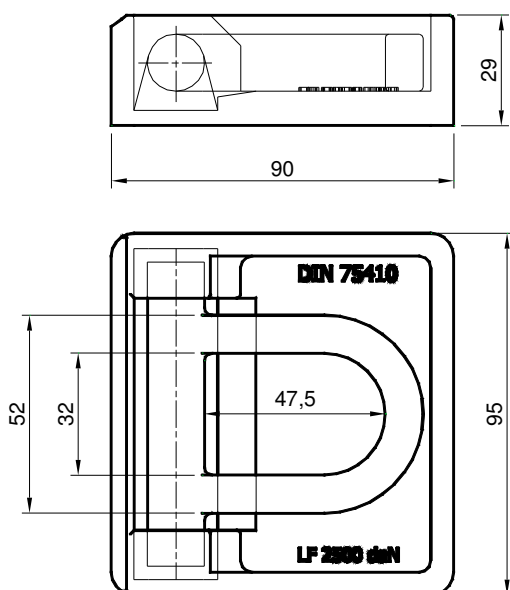
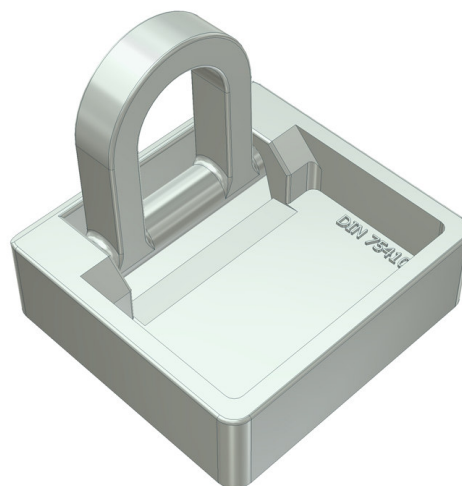

Carico di rottura
Breaking test load
2500 kg

Anello fermacarico a comparsa zincato
Galvanized recessed Lashing ring
Anneau de fixation encastrè zinguè
Anschraub Zurrmulde Verzinkt

Art.45097110 - 0,360 kg

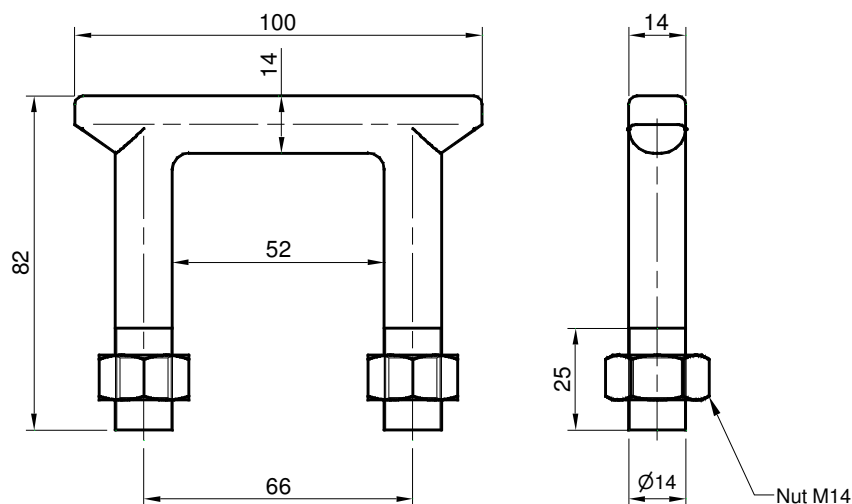

Carico di rottura
Breaking test load
2000 kg

Anello fermacarico a scomparsa fori Ø25
Recessed lashing ring hole Ø25
Anneau de fixation encastré Trou Ø25
Zurmulden halterund und binding Loch Ø25
Verniciato nero / Black painted / Peintè noir / Lackleder

Art.45098310

Grezzo / Raw / Cru / Roh

Art.45098320

0,590 kg

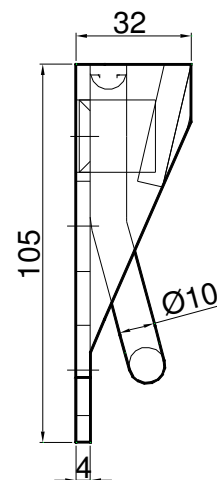
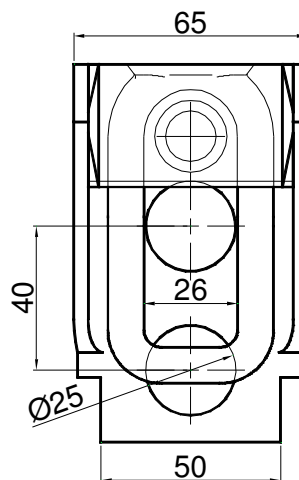
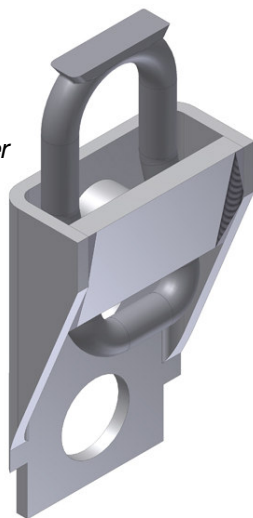

Anello fermacarico a scomparsa zincato fori Ø8,5
Galvanized recessed Lashing ring hole Ø8,5
Anneau de fixation encastré zinguè trou Ø8,5
Anschraub Zurmulde Verzinkt Loch Ø8,5

Art.45098400

0,620 kg

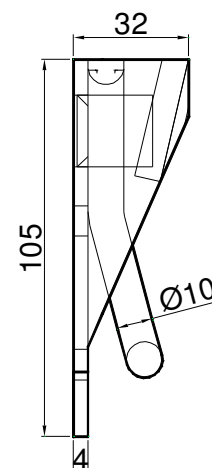
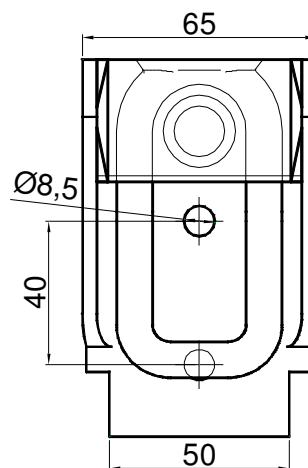
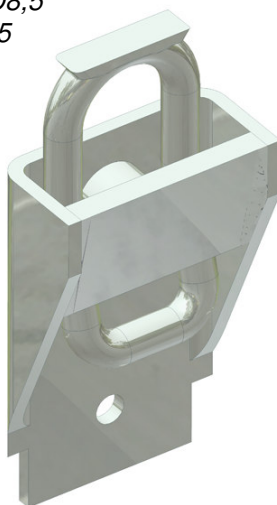

Anello fermacarico a scomparsa ribassato grezzo
Raw recessed low washing ring
Bas anneau de fixation encastrè cru
Niedrig anschraub Zurmulde roh

Art.45098315

0,580 kg

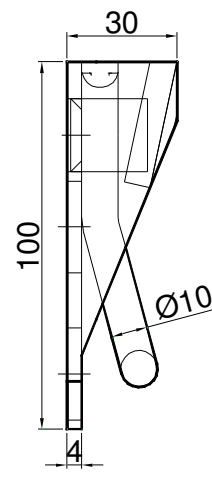
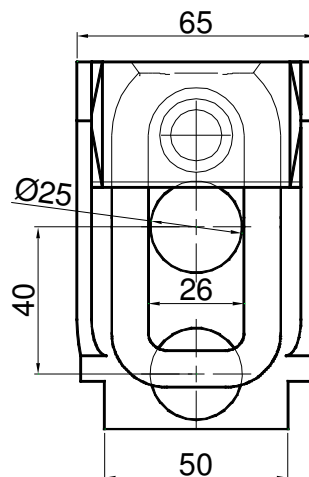
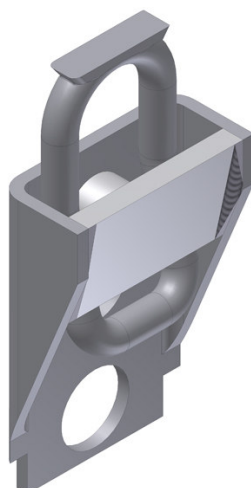

Carico di rottura
Breaking test load
2000 kg

Anello fermacarico a comparsa zincato
Galvanized recessed Lashing ring
Anneau de fixation encastré zingué
Anschraub Zurrmulde Verzinkt
Art.45099110 - 0,360 kg

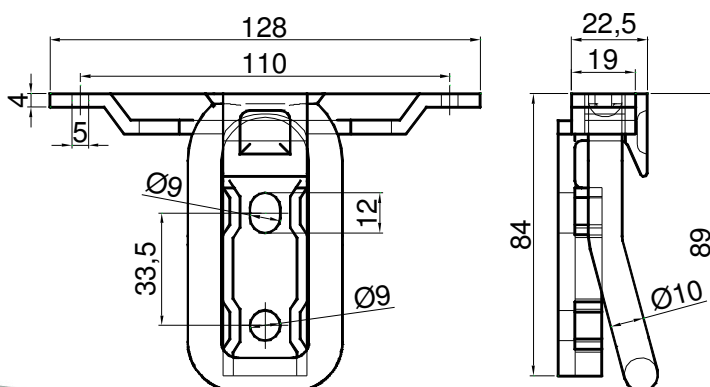
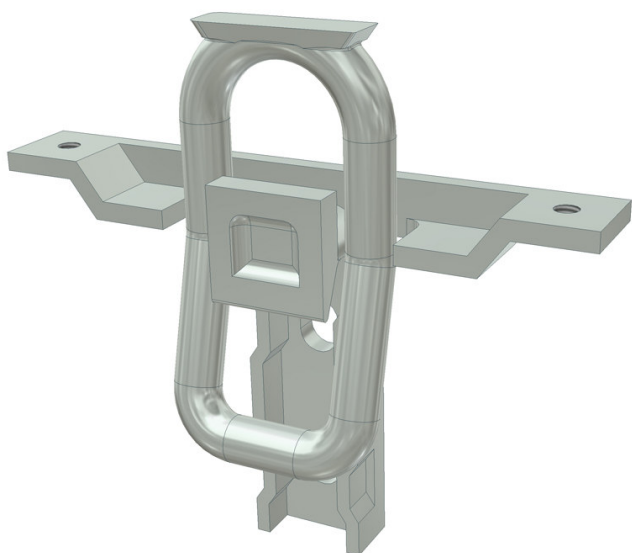

Carico di rottura solo per anello
Breaking test load only for ring
2000 kg

Anello fermacarico a scomparsa zincato dacromet
Dachromed galvanized recessed Lashing ring
Anneau de fixation encastré zingué dachromet
Anschraub Zurrmulde dachromet verzinkt
Art.45096515 - 0,365 kg

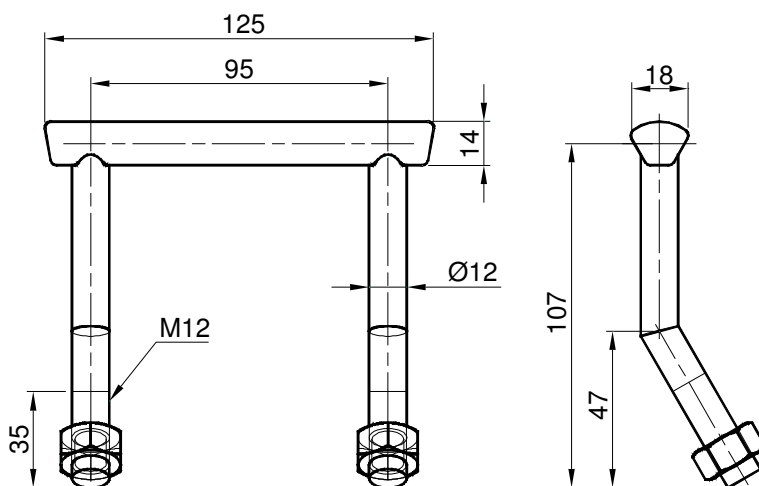

Carico di rottura
Breaking test load
6000 kg



Anello fermacarico zincato a scomparsa con piastra grezza
Galvanized recessed lashing ring with raw plate
Anneau cru de fixation encastré
Roh anschraub Zurrmulde
Art.45096510 - 0,460 kg

Anello fermacarico zincato a scomparsa con piastra zincata
Galvanized recessed lashing ring with galvanized plate
Anneau zinguè de fixation encastré
Anschraub verzinkt zurrmulde
Art.45096511 - 0,460 kg

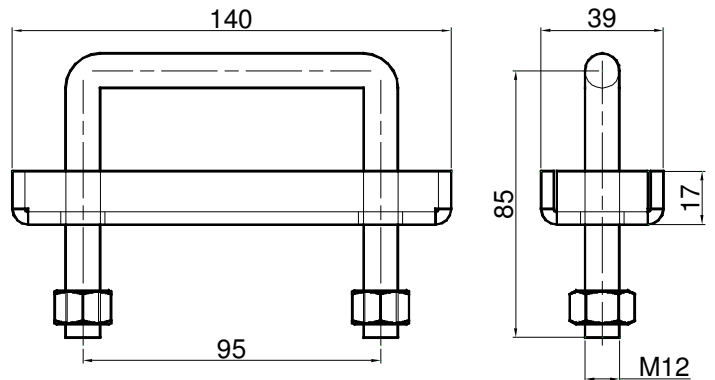
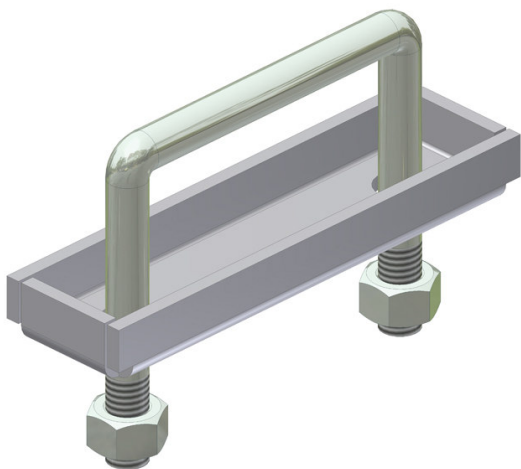

Anello fermacarico zincato
Galvanized lashing ring
Anneau zinguè de fixation
Anschraub verzinkt zurrmulde
Art.45096512 - 0,200 kg

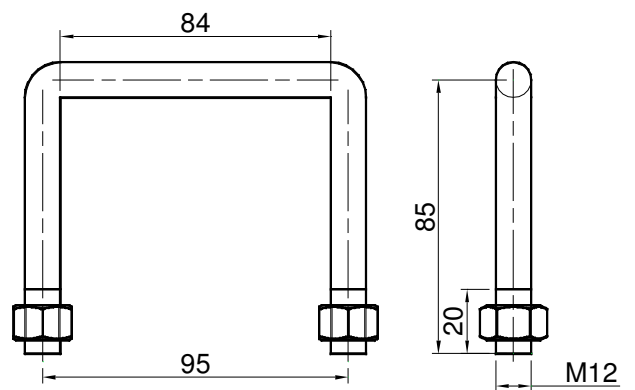

Carico di rottura
Breaking test load
6000 kg

Anello di traino leggero zincato con fermo grezzo da saldare

Galvanized light ring with raw support welded

Anneaux d'arrimage lueur acier brut

Art. 45096822 - 1,200 Kg

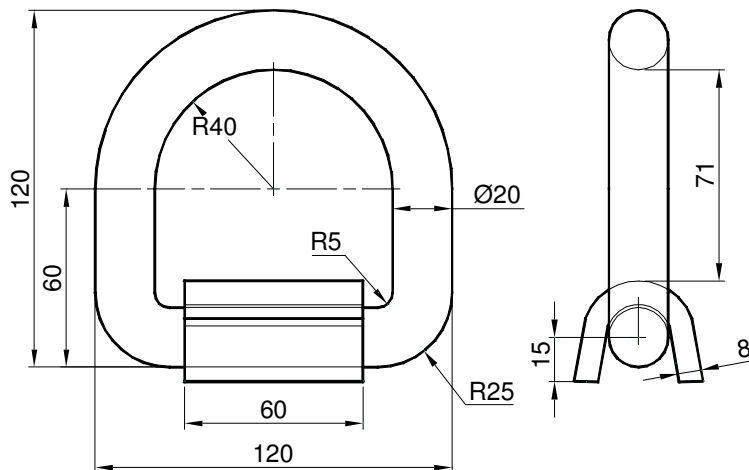

Carico di rottura solo per anello
Breaking test load only for ring
7000 kg

Anello di traino medio grezzo con fermo da saldare

Galvanized medium ring with raw support welded

Anneaux d'arrimage médium acier brut

Art. 45096811 - 2,000 Kg

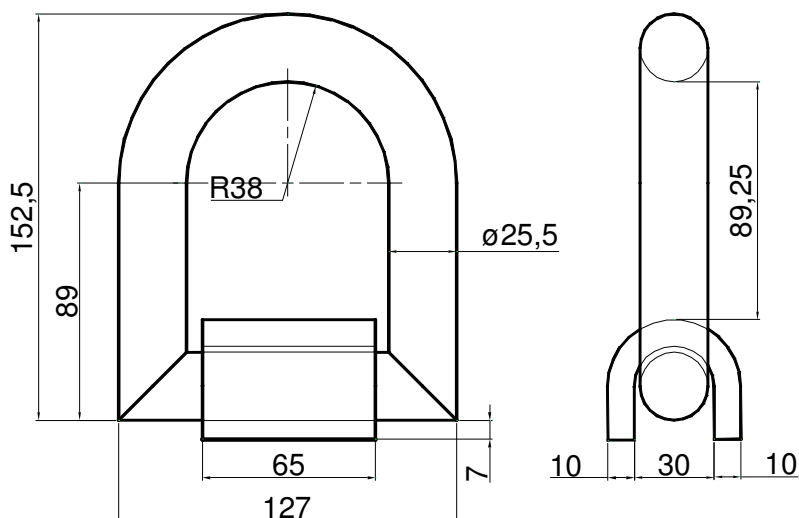

Carico di rottura solo per anello
Breaking test load only for ring
12000 kg

Anello di traino medio zincato con piastra zincata forata
Galvanized medium ring with galv. support with holes
 Anneau d'arrimage médium complet galvanise

Art. 45096831 - 2,600 Kg

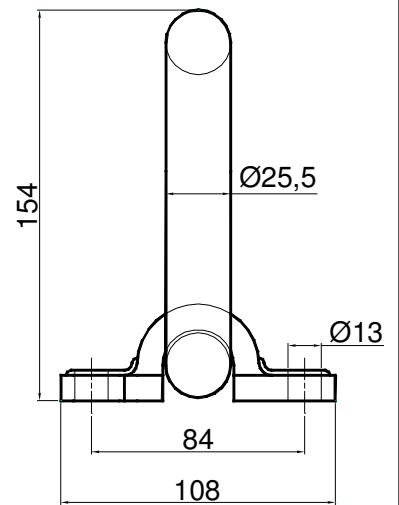
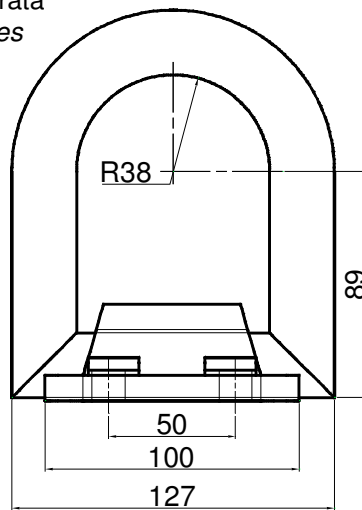

Carico di rottura
Breaking test load
12000 kg

Anello di traino pesante zincato con piastra zincata forata
Galvanized heavy ring with galv. support with holes
 Anneau d'arrimage lourd complet galvanise

Art. 45096832 - 2,900 Kg

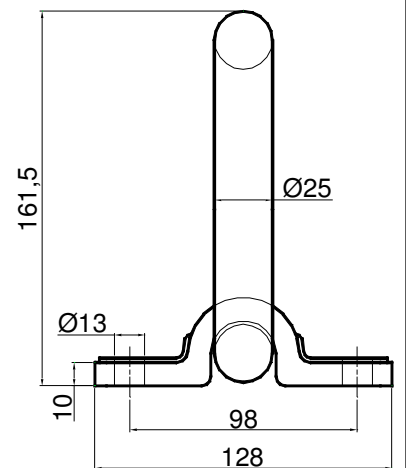
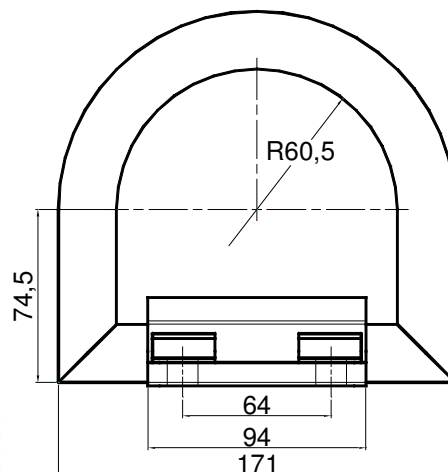

Carico di rottura
Breaking test load
12000 kg

Tendifune Leggero
Light weight rope guide
Tire cable leger
Leichter seilspanner

Art. 45100100 - Grezzo / Raw / Cru / Roh

Art. 45100500 - Inox / Stainless steel / Nirosta
0,055 Kg

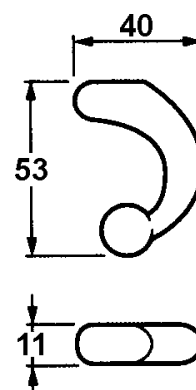

Tendifune Pesante grezzo
Raw Heavy rope guide
Tire cable lourd cru
Schwerer seilspanner roh

Art. 45102100 - 0,110 Kg

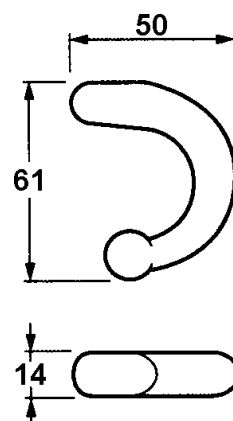

Tendifune Pesantissimo grezzo
Raw Heavy weight rope guide
Tire cable lourd cru
Schwerer seilspanner roh

Art. 45103100 - 0,230 Kg

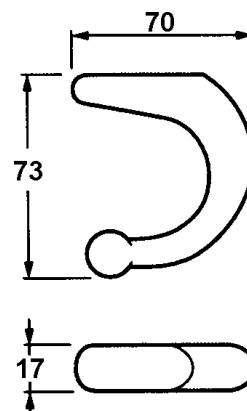

Supporto asta centina zincata
Galvanized steel pocket
 Gousset de rehausse zinguè
 Einsteckaschen verzinkt
Art. 45104130 - 0,220 Kg

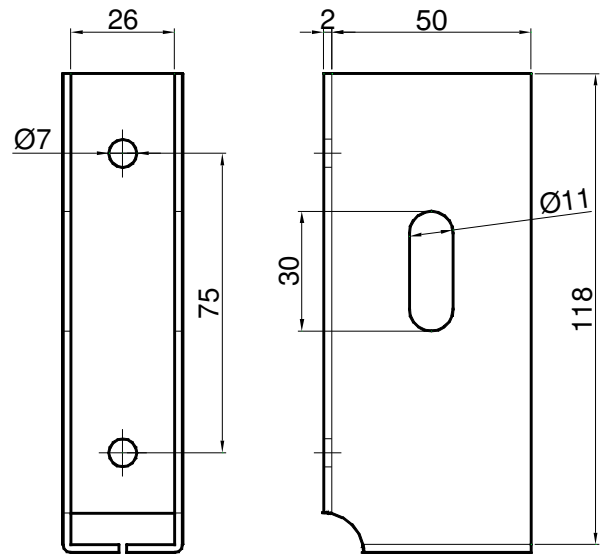

Supporto asta centina grezza L=25
Raw steel pocket L=25
 Gousset de rehausse acier brut L=25
 Einsteckaschen roh L=25
Art. 45150100 - 0,160 Kg

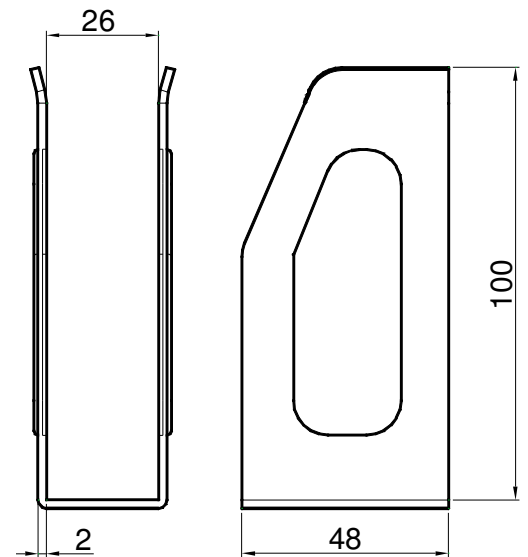
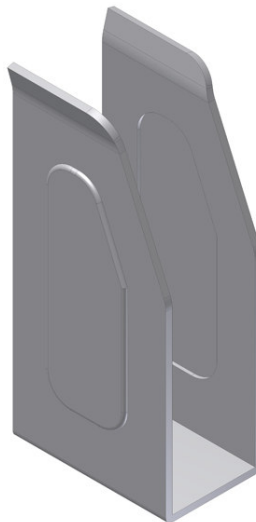

Supporto asta centina grezza L=30
Raw steel pocket L=30
 Gousset de rehausse acier brut L=30
 Einsteckaschen roh L=30
Art. 45152100 - 0,165 Kg

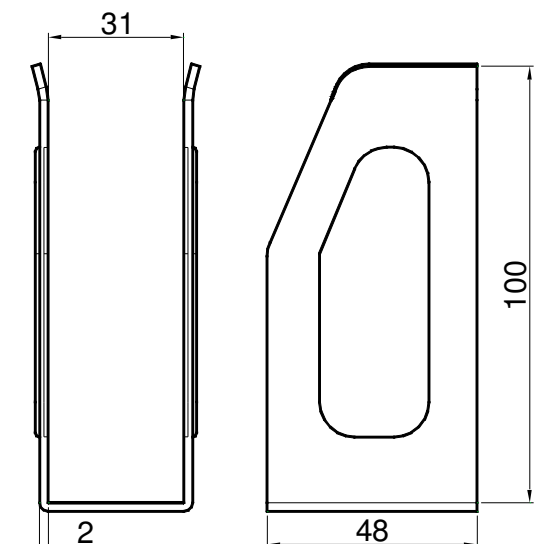
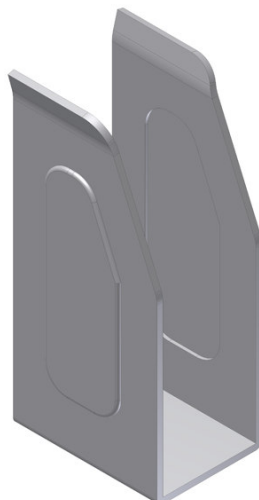

Avvolgicavo "Tourillon"
Drop-Forged steel link pin
 "Tourillon" acier matrice
Art. 45703100 - 1,365 Kg

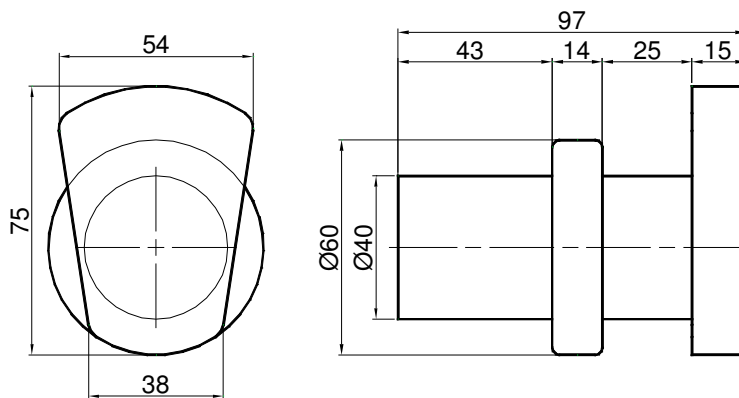
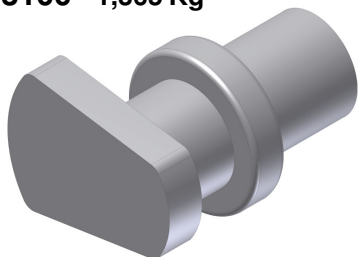

Guida per cassoni scarrabili
Drop-Forged steel tipper thrust block
 Butè de benne PM acier matrice
Art. 45753100 - 1,700 Kg

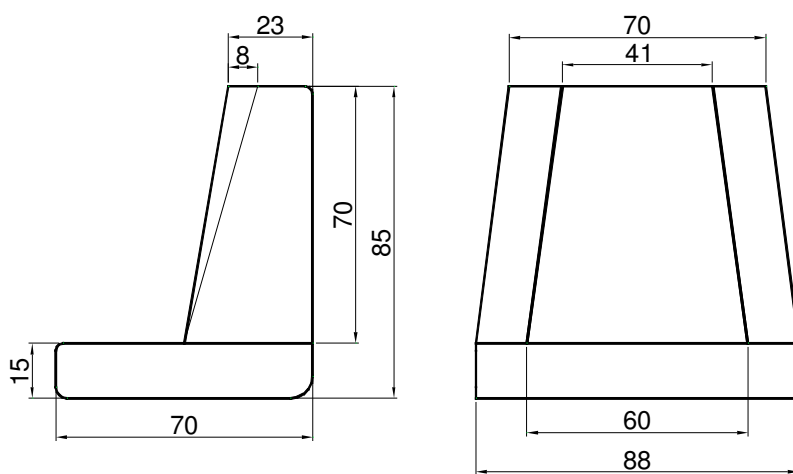
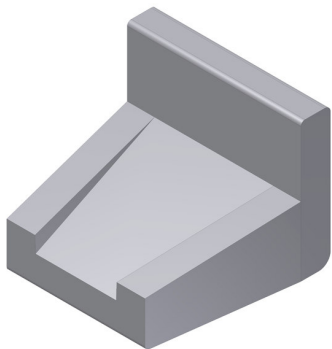

Supporto tubo centina PVC Ø60
Roof member bracket for tube Ø60
 Support de faitiere complet pour tube Ø60
 Planrohhalterung Ø60
Art. 50154285 - 0,100 kg

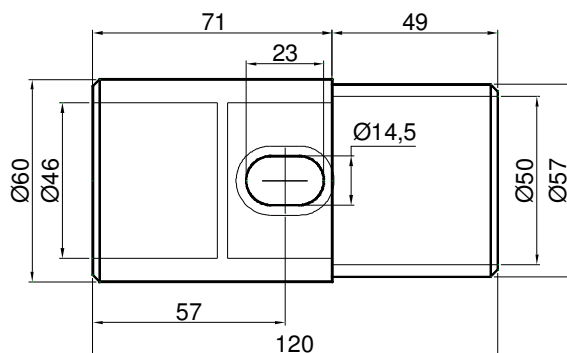

Base L=120 per supporto tubo centina
L=120 Base bracket tube
Art. 50154290 - 0,300 kg

* Solo su ordinazione
 * Only by order

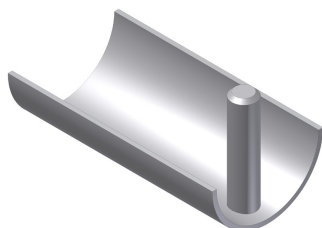

Base L=200 per supporto tubo centina
L=200 Base bracket for tube
Art. 50154295 - 0,530 kg

* Solo su ordinazione
 * Only by order



Supporto tubo centina PVC Ø35
 Roof member bracket for tube Ø35
 Support de faitiere complet pour tube Ø35
 Planrohhalterung Ø35
Art. 45155100 - 0,300 kg

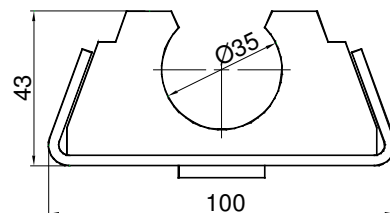
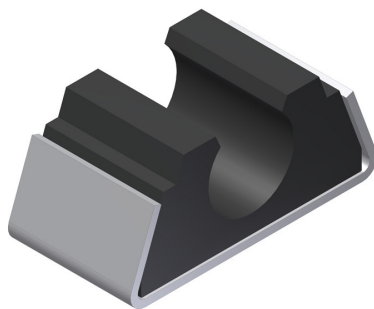

Solo gomma
 Only rubber
Art. 45155101 - 0,140 kg

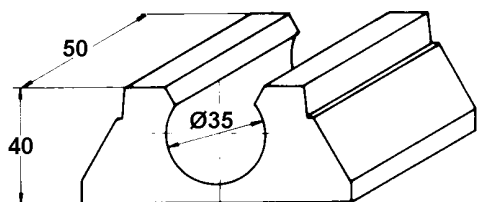

Solo piastrina
 Only plate
Art. 45155102 - 0,160 kg

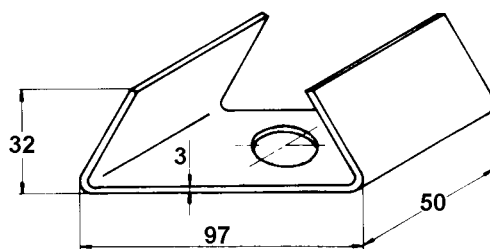

Supporto tubo centina PVC Ø50
 Roof member bracket for tube Ø50
 Support de faitiere complet pour tube Ø50
 Planrohhalterung Ø50
Art. 45151100 - 0,420 kg

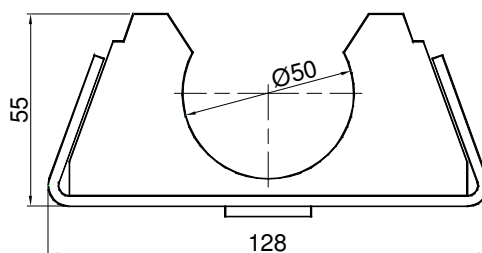
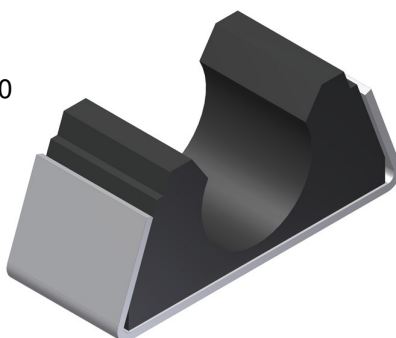

Solo gomma
 Only rubber
Art. 45151101 - 0,215 kg

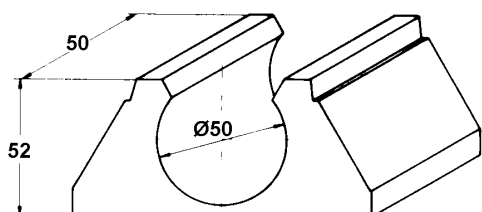

Solo piastrina
 Only plate
Art. 45151102 - 0,205 kg

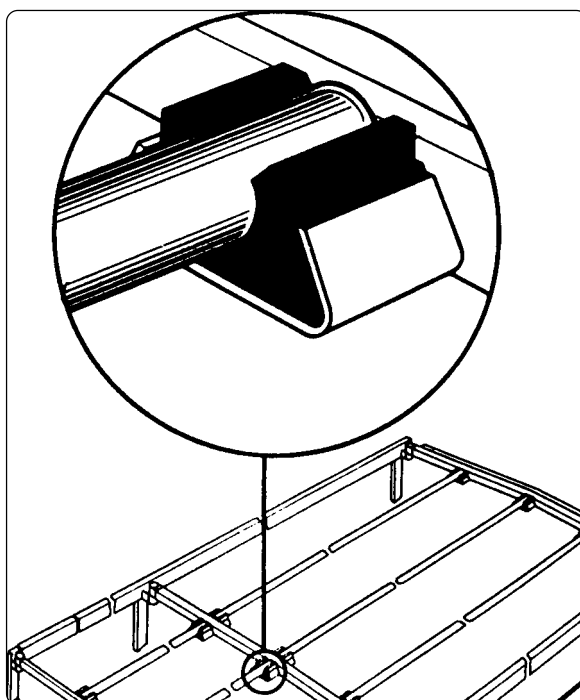
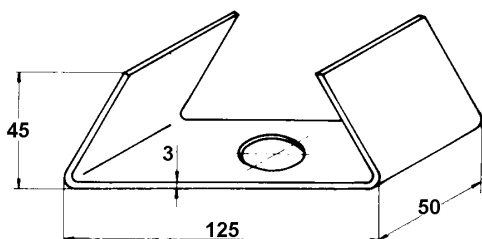

Supporto fissaggio chassis zincato
Body clamp in galvanized drop-forged steel
 Bride de fixation chassis, zinguè
Art. 45191110 - 0,640 kg

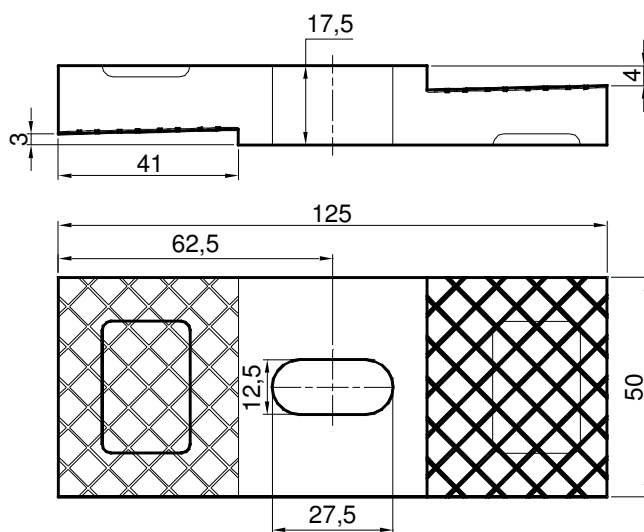

Supporto fissaggio chassis zincato spessori 7/8 - 10/12
Body clamp in galv. drop-forged steel-chassis thichness 7/8 - 10/12
 Bride de fixation chassis, zinguè d'èpaisseur de 7/8 - 10/12
Art. 45291110 - 0,700 kg

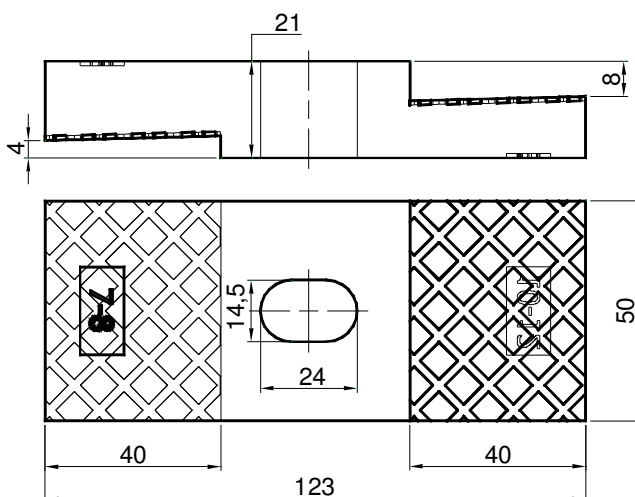
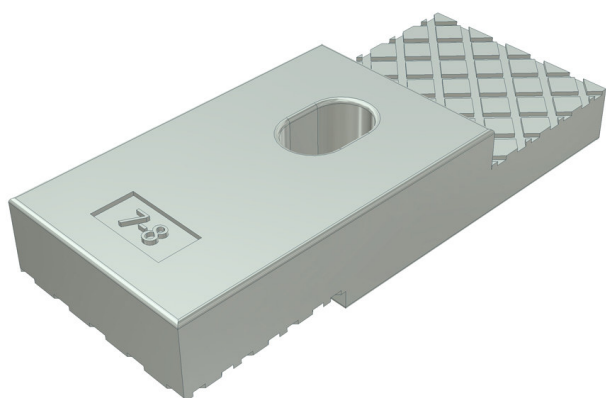

Supporto fissaggio chassis zincato
Body clamp in galvanized drop-forged steel
 Bride de fixation chassis, zinguè
Art. 45190110 - 1,200 kg

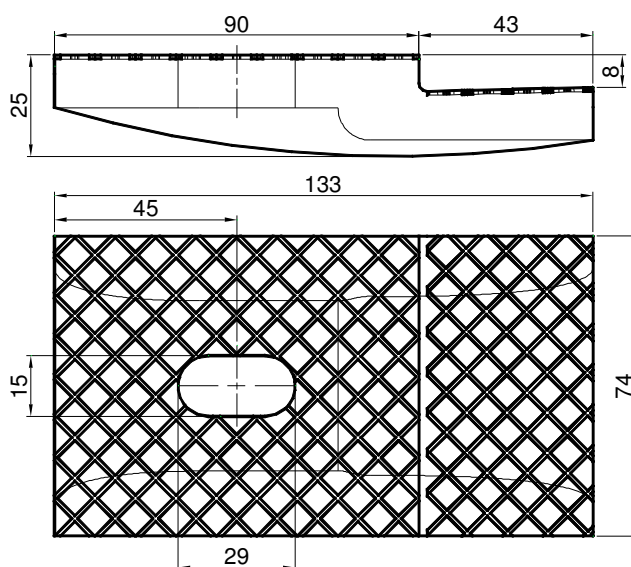

Supporto fissaggio chassis zincato spessori 4/5 - 5/6
Body clamp in galvanized drop-forged steel-chassis thickness 4/5 - 5/6
 Bride de fixation chassis, zinguè d'epaisseur de 4/5 - 5/6

Art. 45287110 - 0,820 kg

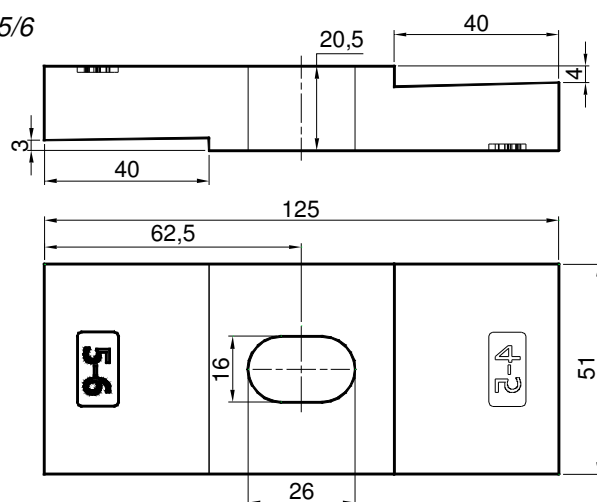

Supporto fissaggio chassis zincato spessori 7/8 - 10/12
Body clamp in galv. drop-forged steel-chassis thickness 7/8 - 10/12
 Bride de fixation chassis, zinguè d'epaisseur de 7/8 - 10/12

Art. 45292110 - 0,700 kg

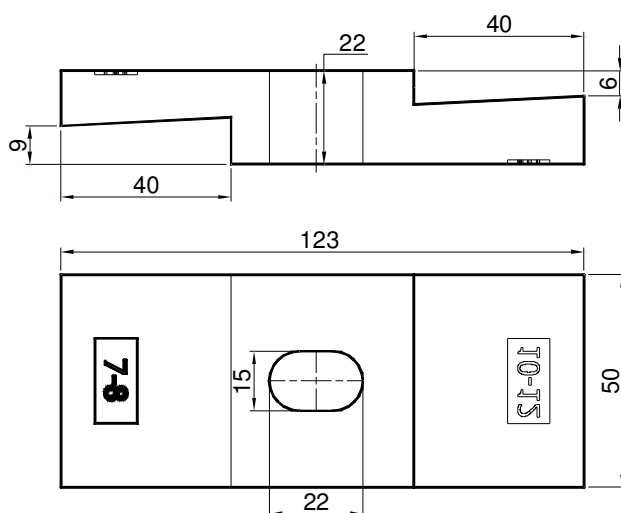
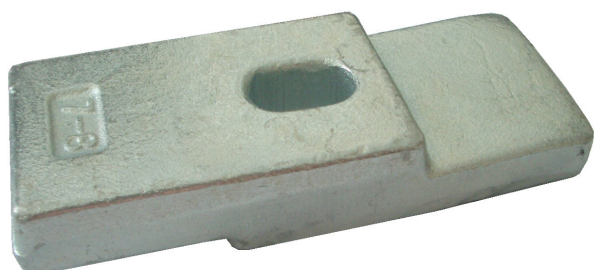

Supporto fissaggio chassis zincato spessori 10/12 - 14/16
Body clamp in galv. drop-forged steel-chassis thickness 10/12 - 14/16
 Bride de fixation chassis, zinguè d'epaisseur de 10/12 - 14/16

Art. 45187110 - 1,090 kg

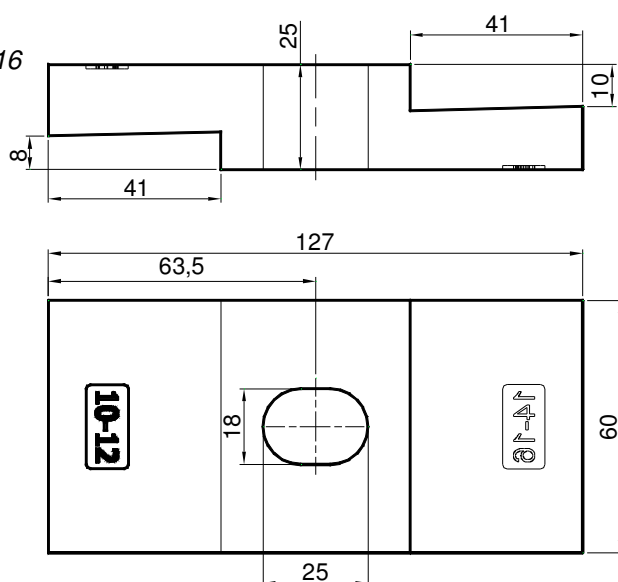

Supporto falso di telaio grezzo
Raw body mounting brackets
Brueckenbefestigung roh
Support faux chassis brut
Art. 45388100 - 0,300 kg

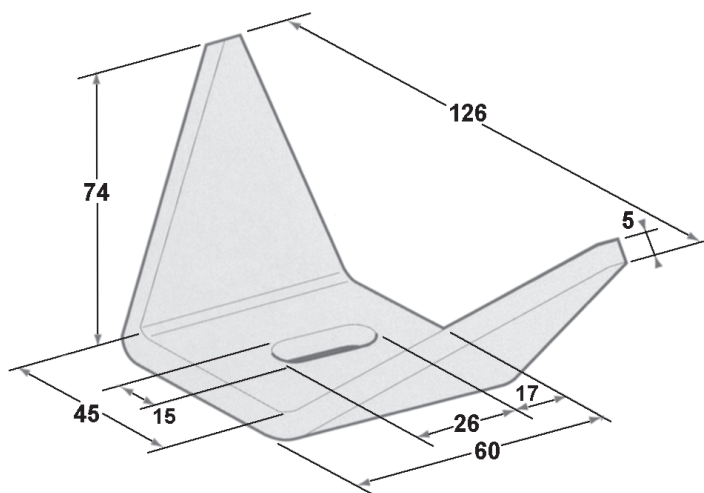

Supporto falso di telaio pesante grezzo
Raw heavy body mounting brackets
Brueckenbefestigung roh
Support faux chassis brut
Art. 45399100 - 0,500 kg

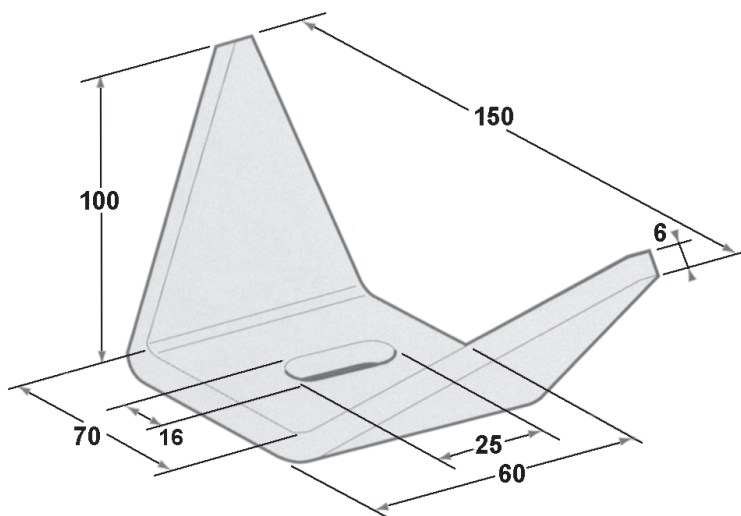

Supporto falso telaio M.A.N.
M.A.N. body mounted bracket
 Support faux chassis M.A.N.
Bruekenbefestigung
 Grezzo - Raw - Brut - Roh

Art. 45186100

Zincato - Galvanized - Zinguè - Verzinkt

Art. 45189100

0,600 kg

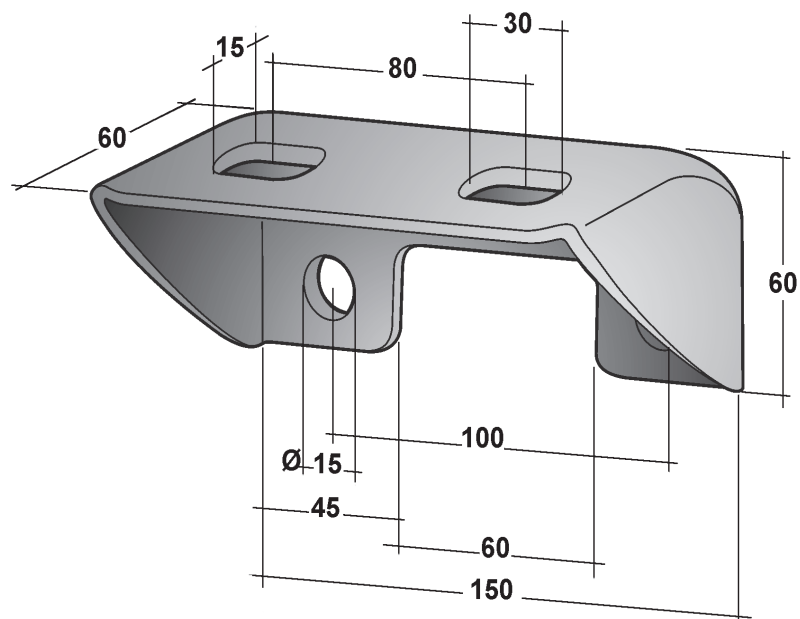

Supporto falso telaio EUROCARGO
EUROCARGO body mounted bracket
 Support faux chassis EUROCARGO
Bruekenbefestigung EUROCARGO
 Grezzo - Raw - Brut - Roh

Art. 45164100

Zincato - Galvanized - Zinguè - Verzinkt

Art. 45165110

0,630 kg

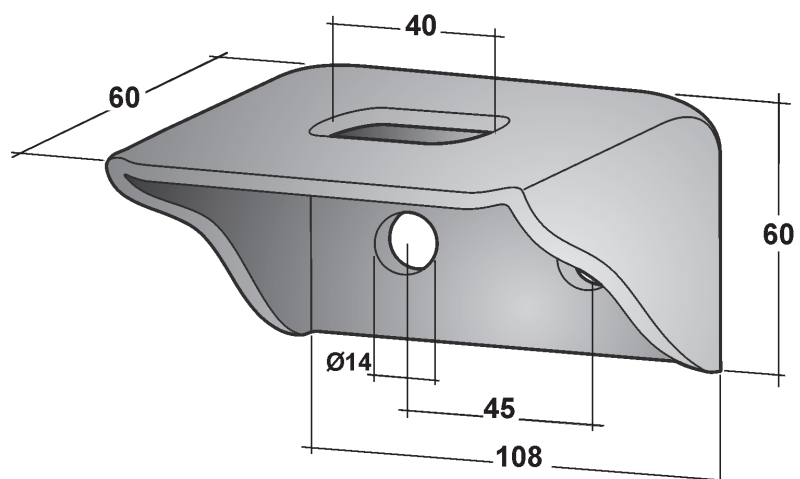

Supporto falso telaio ACTROS
ACTROS body mounted bracket
 Support faux chassis ACTROS
Bruekenbefestigung ACTROS
 Grezzo - Raw - Brut - Roh

Art. 45178100

Zincato - Galvanized - Zinguè - Verzinkt

Art. 45178110

0,870 kg

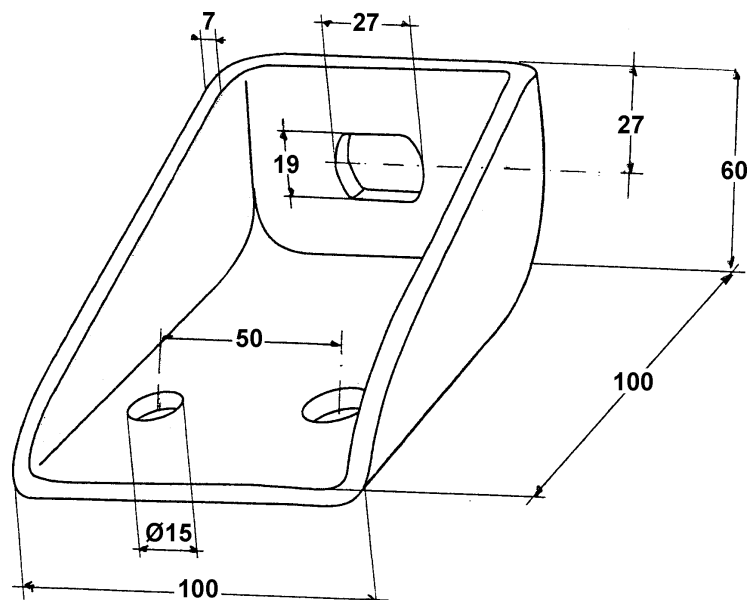

Supporto falso telaio leggero
Light body mounted bracket
Support faux chassis
Brueckenbefestigung
Grezzo - Raw - Brut - Roh

Art. 45166100

Zincato - *Galvanized* - Zinguè - *Verzinkt*

Art. 45163100

0,320 kg

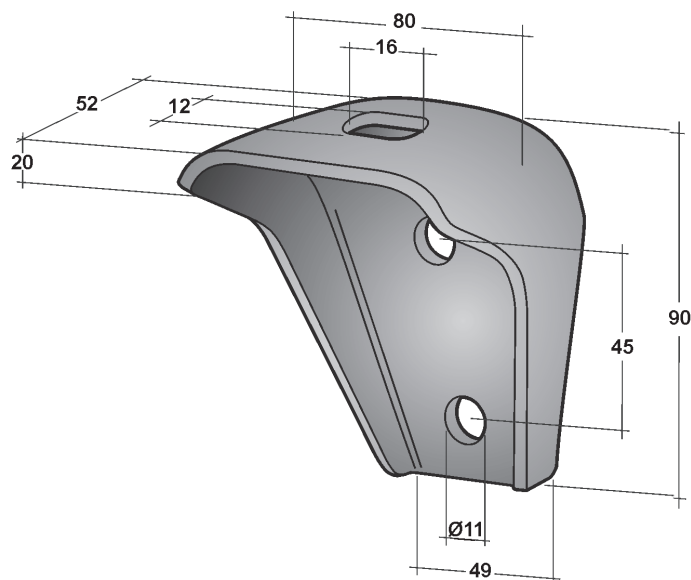

Supporto falso telaio leggero
Light body mounted bracket
Support faux chassis
Brueckenbefestigung
Grezzo - Raw - Brut - Roh

Art. 45166200

Zincato - *Galvanized* - Zinguè - *Verzinkt*

Art. 45163200

0,300 kg

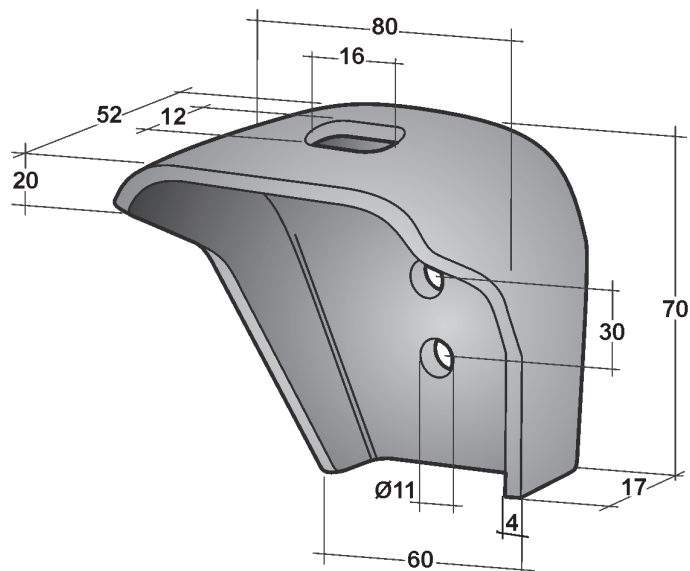

Supporto falso telaio
Body mounted bracket
Support faux chassis
Brueckenbefestigung

Zincato - *Galvanized* - Zinguè - *Verzinkt*

Art. 45163300

0,450 kg

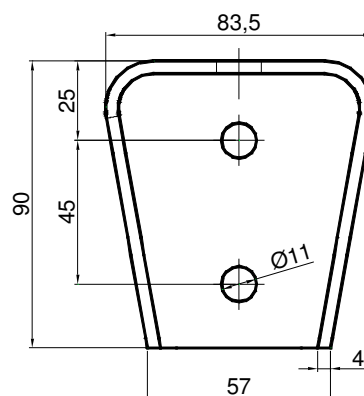
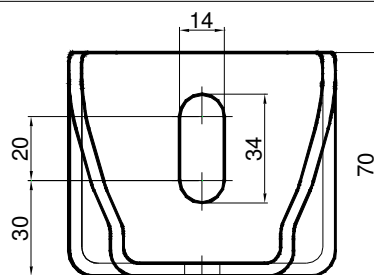

Supporto falso telaio pesante
Heavy body mounted bracket
Support faux chassis
Bruekenbefestigung

Grezzo - Raw - Brut - Roh

Art. 45170100

Zincato - Galvanized - Zinguè - Verzinkt

Art. 45181100

0,970 kg

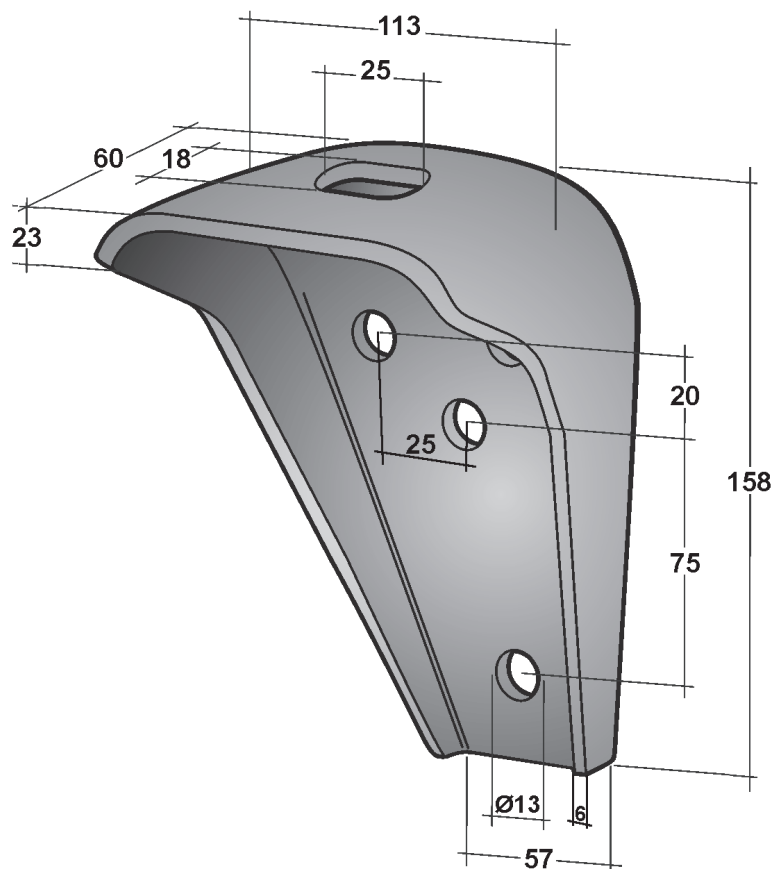

Supporto falso telaio pesante
Heavy body mounted bracket
Support faux chassis
Bruekenbefestigung

Grezzo - Raw - Brut - Roh

Art. 45172100

Zincato - Galvanized - Zinguè - Verzinkt

Art. 45172110

0,720 kg

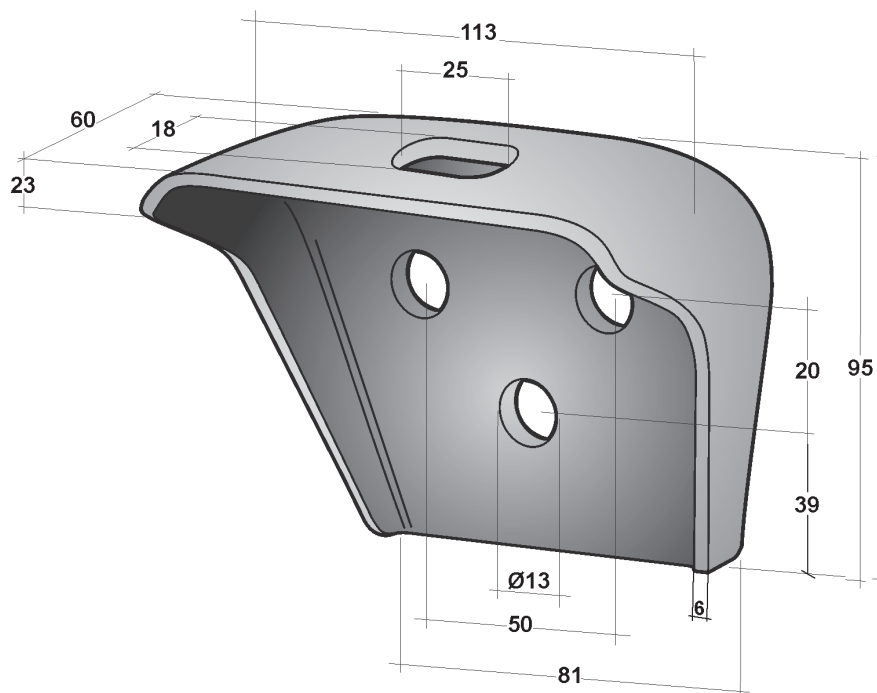

Supporto falso telaio grezzo tipo Francia
France type raw body mounted bracket
Support faux chassis brut
Brueckenbefestigung roh

Art. 45167100

0,370 kg

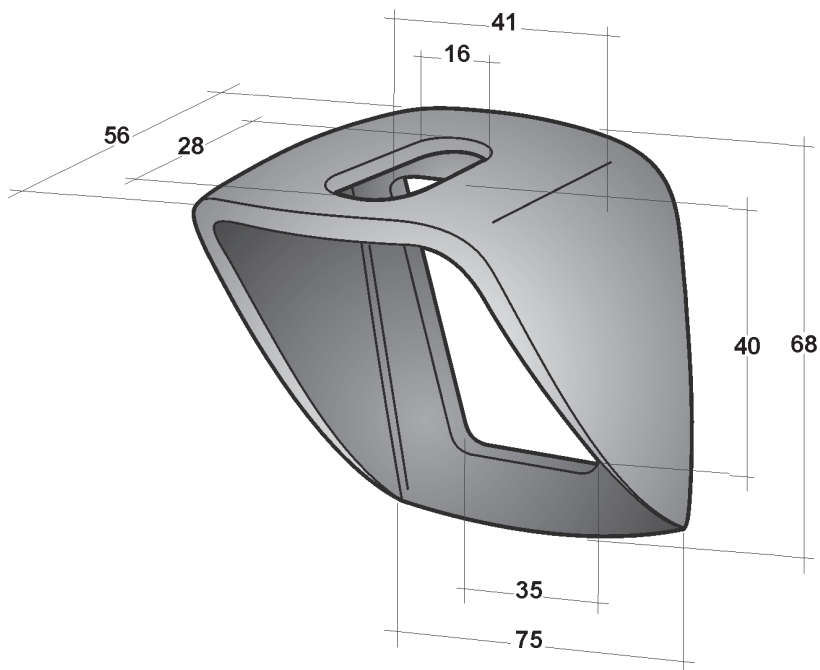
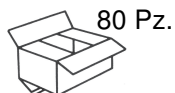

Supporto falso telaio
Body mounted bracket
Support faux chassis
Brueckenbefestigung
Grezzo - Raw - Brut - Roh

Art. 45169100

Zincato - *Galvanized* - Zinguè - *Verzinkt*

Art. 45177100

0,580 kg

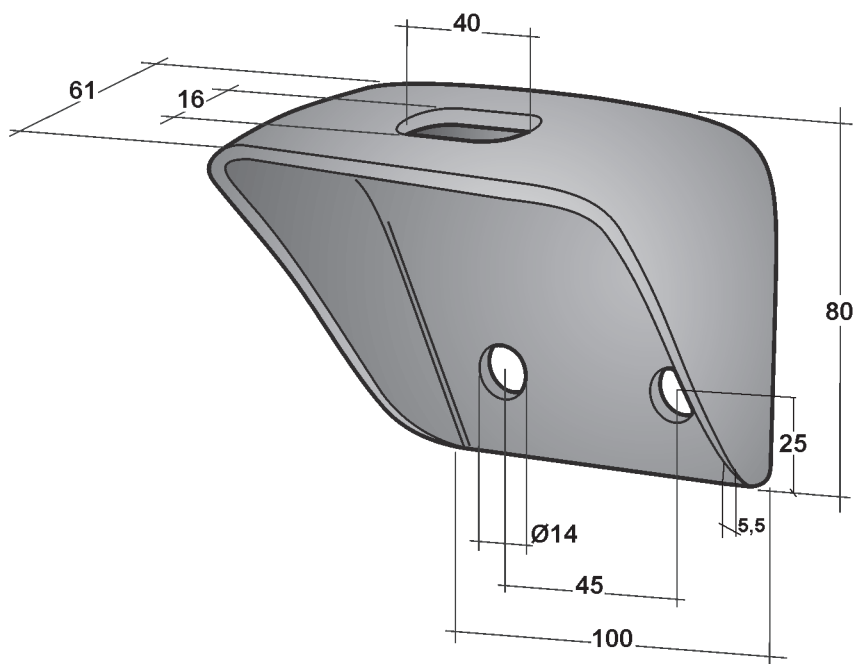

Supporto Volvo H=150 mm grezzo
Raw Volvo support H=150 mm
 Support faux chassis brut Volvo H=150 mm
Roh brueckenbefestigung Volvo H=150 mm
Art. 45257100 - 0,800 kg

Supporto Volvo H=150 mm zincato
Galvanised Volvo support H=150 mm
 Support faux chassis Volvo H=150 mm zinguè
Verzinkt brueckenbefestigung Volvo H=150 mm
Art. 45278110 - 0,800 kg

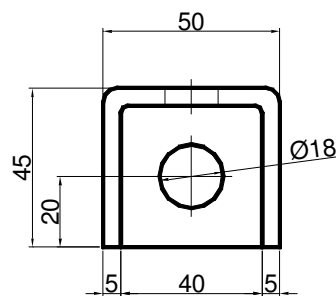
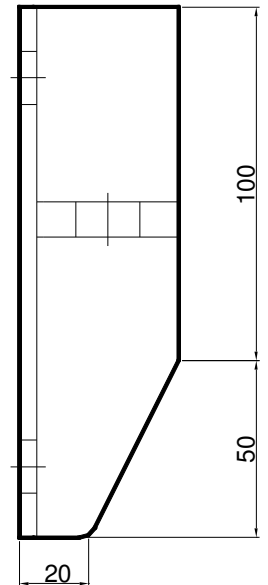
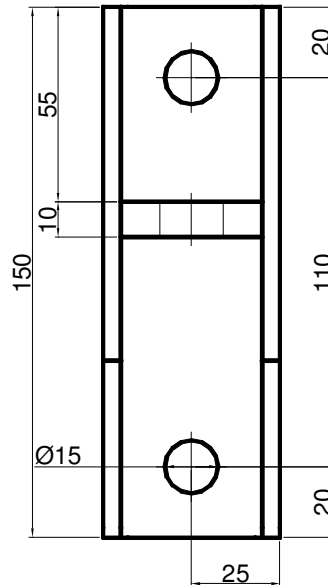
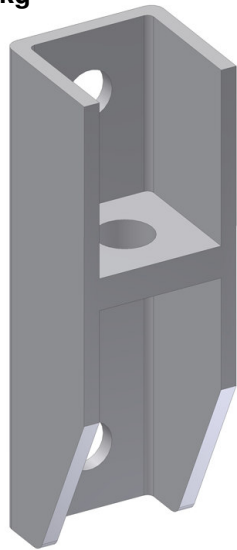

Supporto Volvo H=115 mm grezzo
Raw Volvo support H=115 mm
 Support faux chassis brut Volvo H=115 mm
Roh brueckenbefestigung Volvo H=115 mm
Art. 45256100 - 0,600 kg

Supporto Volvo H=115 mm zincato
Galvanised Volvo support H=115 mm
 Support faux chassis Volvo H=115 mm zinguè
Verzinkt brueckenbefestigung Volvo H=115 mm
Art. 45276100 - 0,600 kg

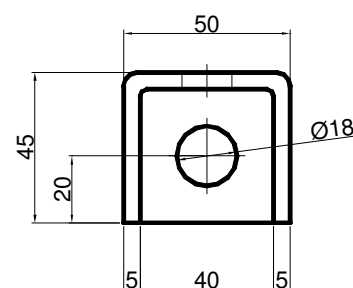
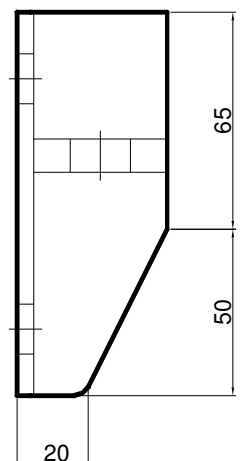
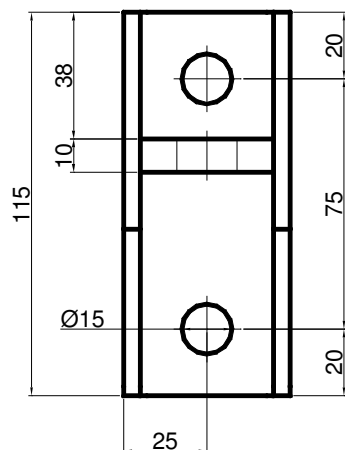
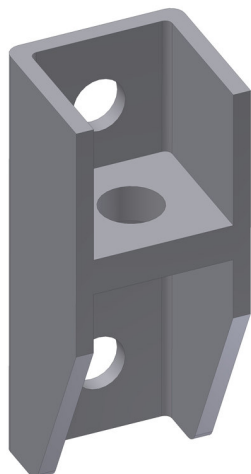

Supporto Volvo H=195 mm grezzo
Raw Volvo support H=195 mm
 Support faux chassis brut Volvo H=195 mm
Roh brueckenbefestigung Volvo H=195 mm
Art. 45258100 - 0,860 kg

Supporto Volvo H=195 mm zincato
Galvanised Volvo support H=195 mm
 Support faux chassis Volvo H=195 mm zinguè
Verzinkt brueckenbefestigung Volvo H=195 mm
Art. 45258110 - 0,860 kg

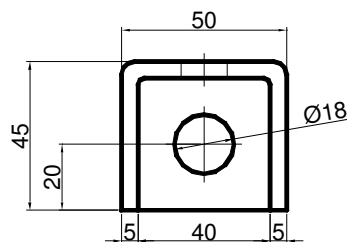
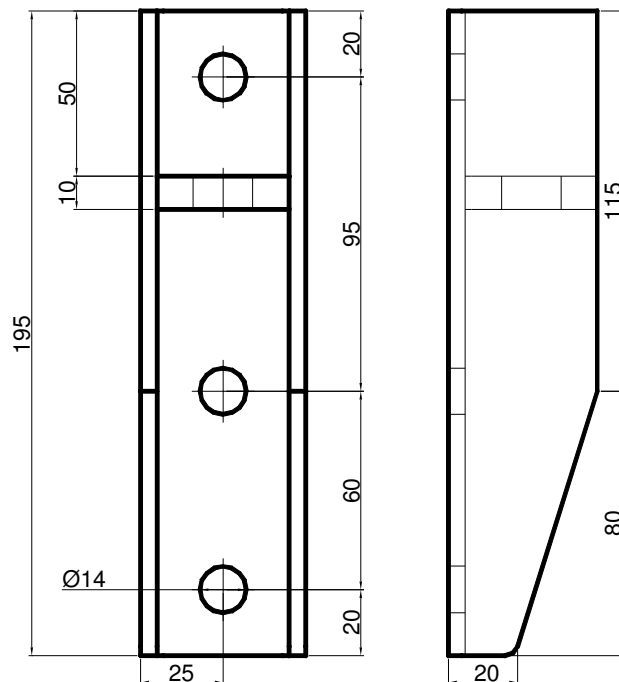
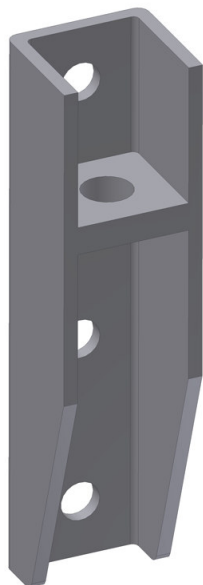

Supporto Volvo H=91 mm grezzo
Raw Volvo support H=91 mm
 Support faux chassis brut Volvo H=91 mm
Roh brueckenbefestigung Volvo H=91 mm
Art. 45254100 - 0,500 kg

Supporto Volvo H=91 mm zincato
Galvanised Volvo support H=91 mm
 Support faux chassis Volvo H=91 mm zinguè
Verzinkt brueckenbefestigung Volvo H=91 mm
Art. 45274110 - 0,500 kg

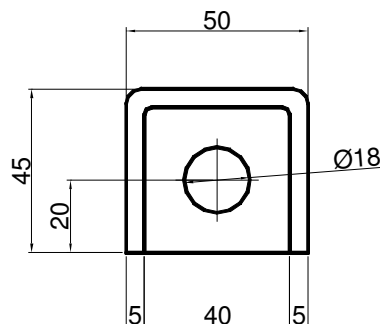
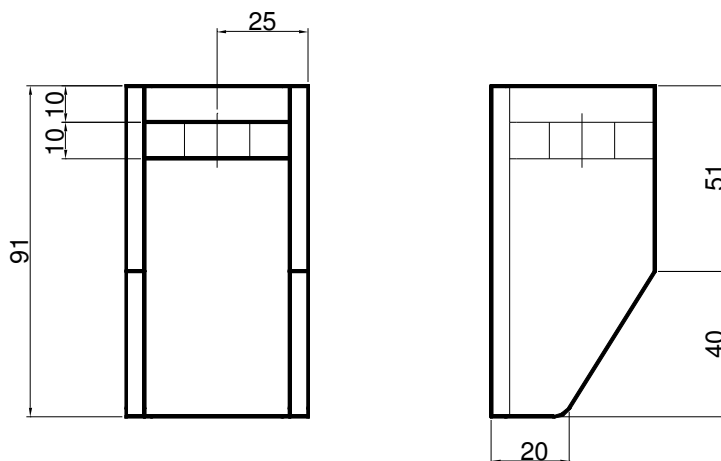
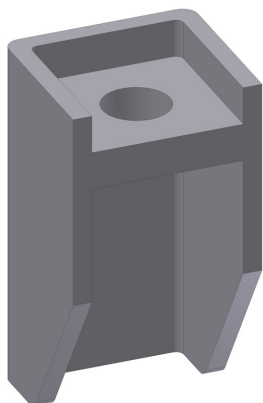

Supporto Volvo H=100 mm grezzo
Raw Volvo support H=100 mm
 Support faux chassis brut Volvo H=100 mm
Roh brueckenbefestigung Volvo H=100 mm
Art. 45280100 - 0,550 kg

Supporto Volvo H=100 mm zincato
Galvanised Volvo support H=100 mm
 Support faux chassis Volvo H=100 mm zinguè
Verzinkt brueckenbefestigung Volvo H=100 mm
Art. 45280110 - 0,550 kg

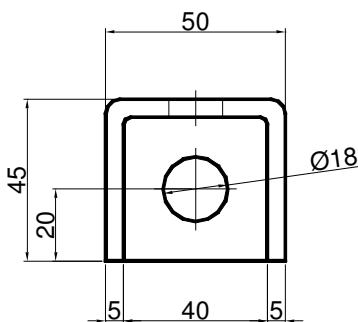
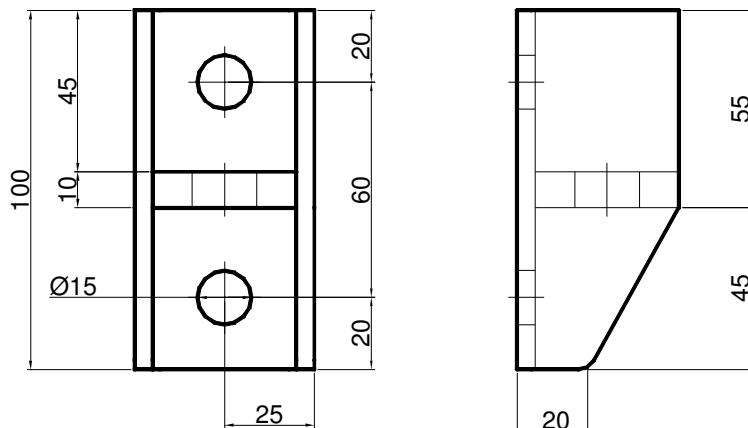
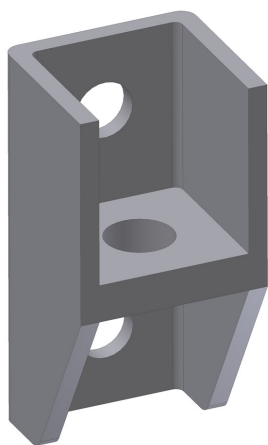

Supporto Volvo H=120 mm zincato
Galvanised Volvo support H=120 mm
 Support faux chassis Volvo H=120 mm zinguè
Verzinkt brueckenbefestigung Volvo H=120 mm
Art. 45281110 - 0,620 kg

Supporto Volvo H=120 mm verniciato
Painted Volvo support H=120 mm
 Support faux chassis Volvo H=120 mm peintè
Brueckenbefestigung Volvo H=120 mm gestrichen
Art. 45281210 - 0,620 kg

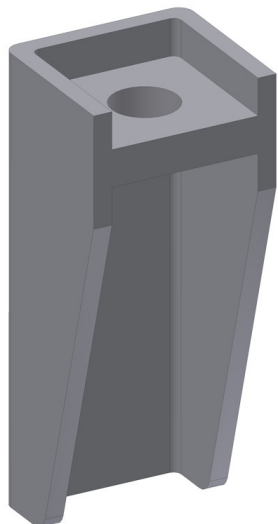

Supporto Volvo H=120 mm grezzo
Raw Volvo support H=120 mm
 Support faux chassis brut Volvo H=120 mm
Roh brueckenbefestigung Volvo H=120 mm
Art. 45281100 - 0,620 kg

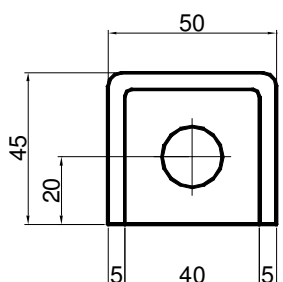
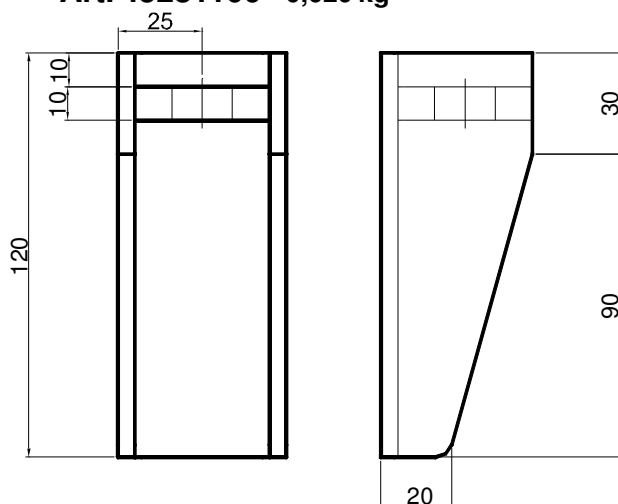

Supporto Volvo H=125 mm grezzo
Raw Volvo support H=125 mm
Support faux chassis brut Volvo H=125 mm
Roh brueckenbefestigung Volvo H=125 mm
Art. 45404030 - 0,900 kg

Supporto Volvo H=125 mm verniciato
Painted Volvo support H=125 mm
Support faux chassis Volvo H=125 mm peintè
Rostschutzlack brueckenbefestigung Volvo H=125mm
Art. 45404230 - 0,900 kg

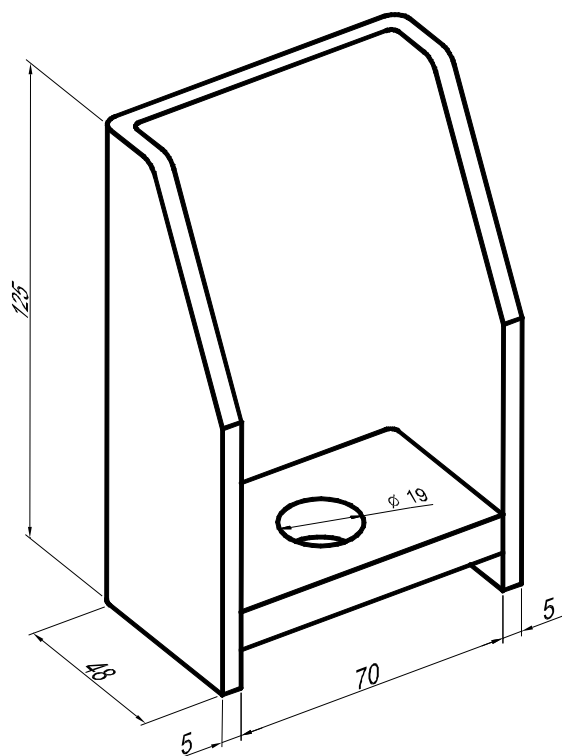

Contropiastra per supporto verniciata
Painted plate for support chassis
Contreplaque pour support peinté
Brueckenbefestigung platte lackiert
Art. 45404231 - 0,125 kg

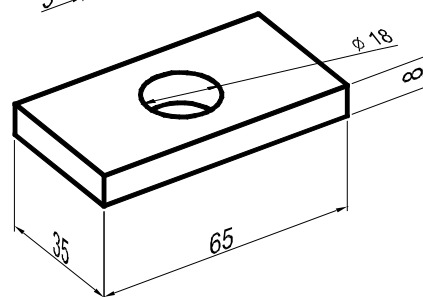

Supporto
Support
Support
Bruekenbefestigung
Grezzo - Raw - Brut - Roh

Art. 45283100

Verniciato - Painted - Peintè - Lack

Art. 45283200

1,170 kg

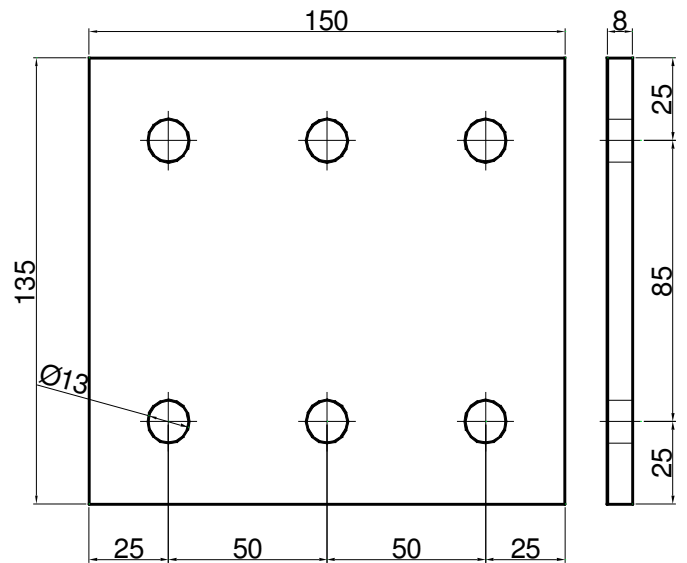
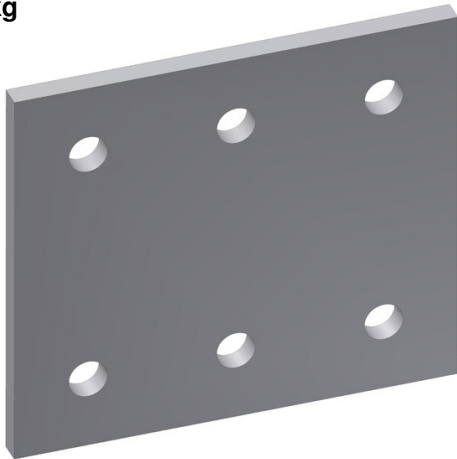

Supporto M736
Support M736
Support M736
Bruekenbefestigung M736
Grezzo - Raw - Brut - Roh

Art. 45282100

Verniciato - Painted - Peintè - Lack

Art. 45282200

1,750 kg

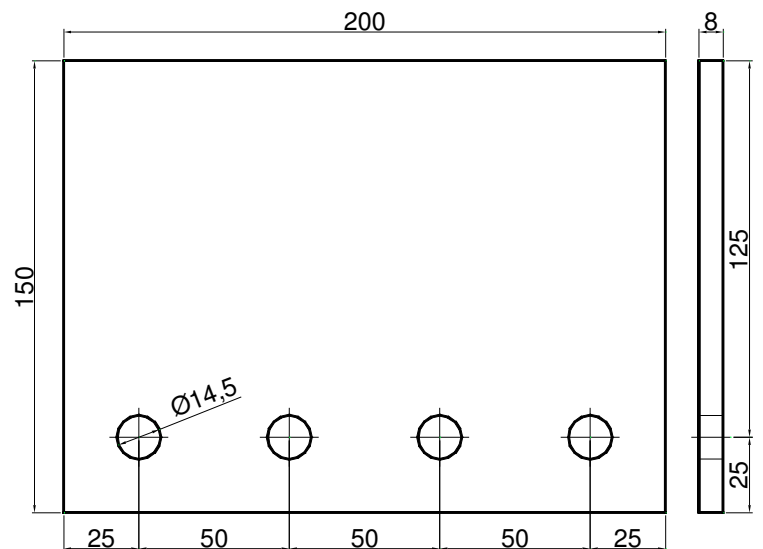

Supporto SCANIA
 SCANIA Support
 Support SCANIA
 Brueckenbefestigung SCANIA
 Grezzo - Raw - Brut - Roh

Art. 45383100

Verniciato - Painted - Peintè - Lack

Art. 45383120

0,790 kg

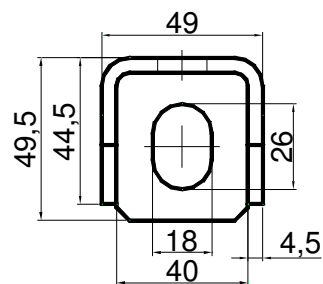
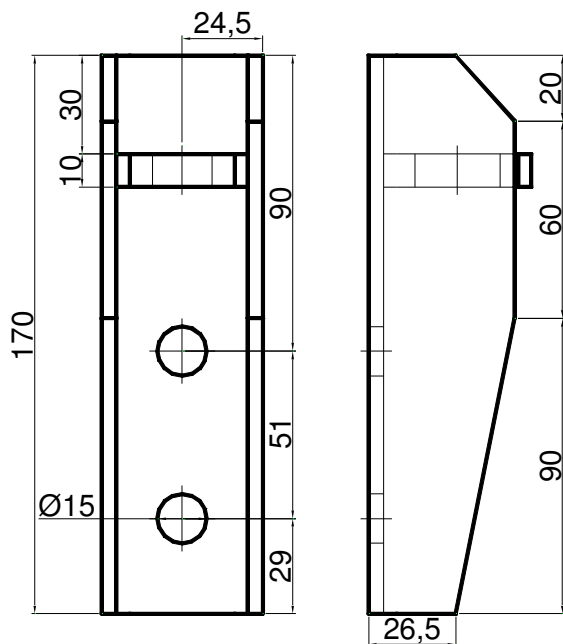
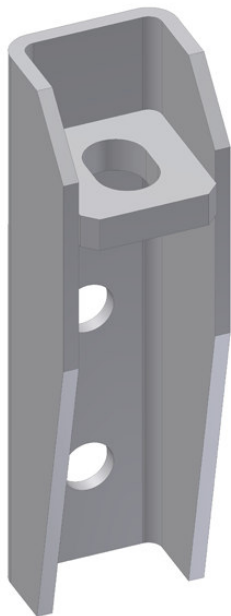

Supporto SCANIA
 SCANIA Support
 Support SCANIA
 Brueckenbefestigung SCANIA
 Grezzo - Raw - Brut - Roh

Art. 45383300

Verniciato - Painted - Peintè - Lack

Art. 45383320

2,430 kg

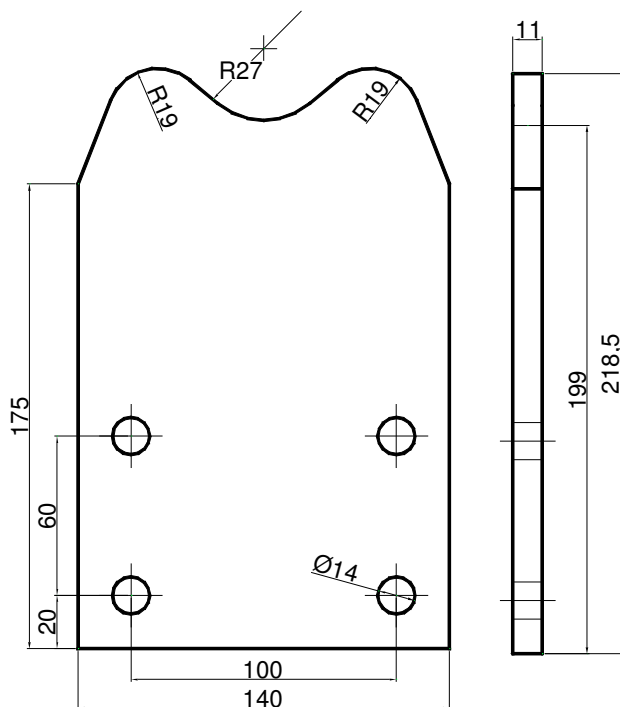
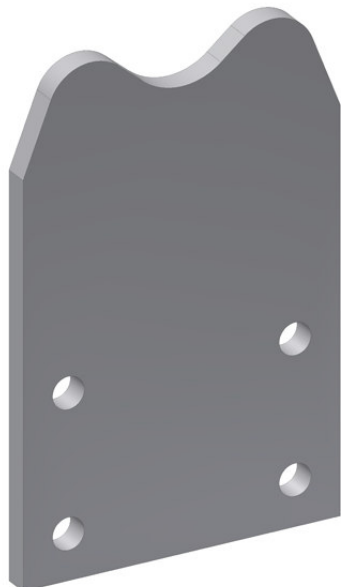

Supporto falso telaio MERCEDES / VOLKSWAGEN
 Body mounting bracket MERCEDES / VOLKSWAGEN
 Brueckenbefestigung MERCEDES / VOLKSWAGEN
 Support faux chassis MERCEDES / VOLKSWAGEN
 Grezzo - Raw - Brut - Roh

Art. 45175100

Zincato - Galvanized - Zinguè - Verzinkt

Art. 45175110

0,470 kg

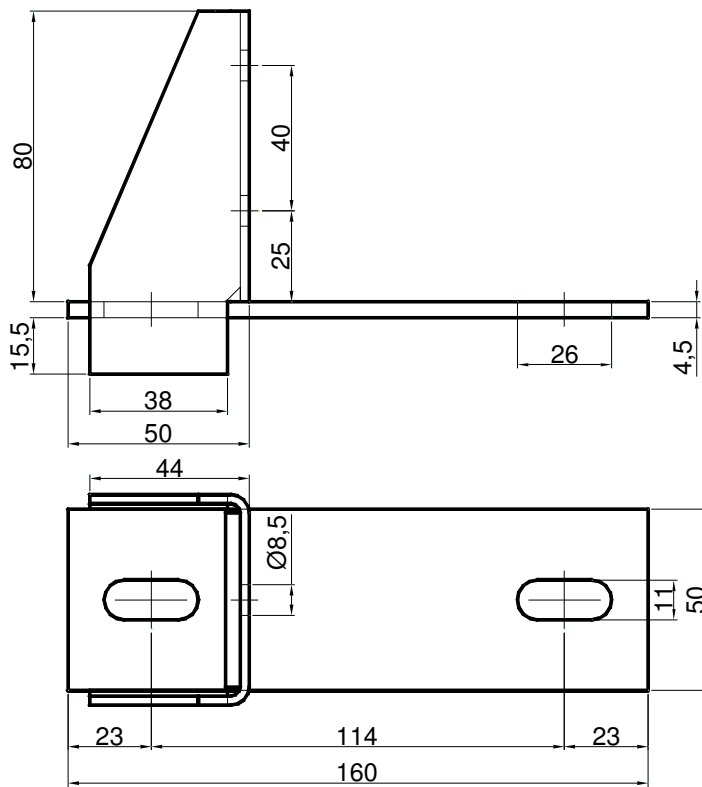
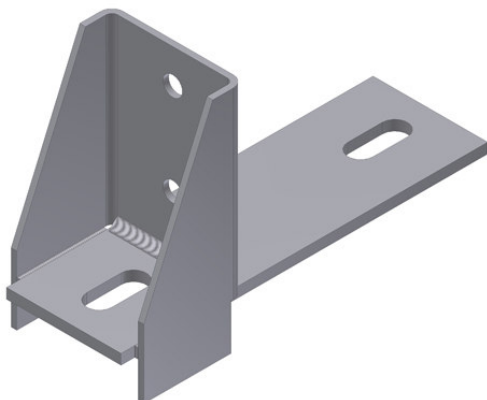

Falso telaio zincato a caldo Universale per ruote gemellate
 Hot galvanized Universal mounting bracket for twin tires
 Fixation de pont Universel zinguè a feu pour roue jumelée
 Feuerverzinkt Brueckenbefestigung doppelbereift

Art. 45175410 - 0,695 kg

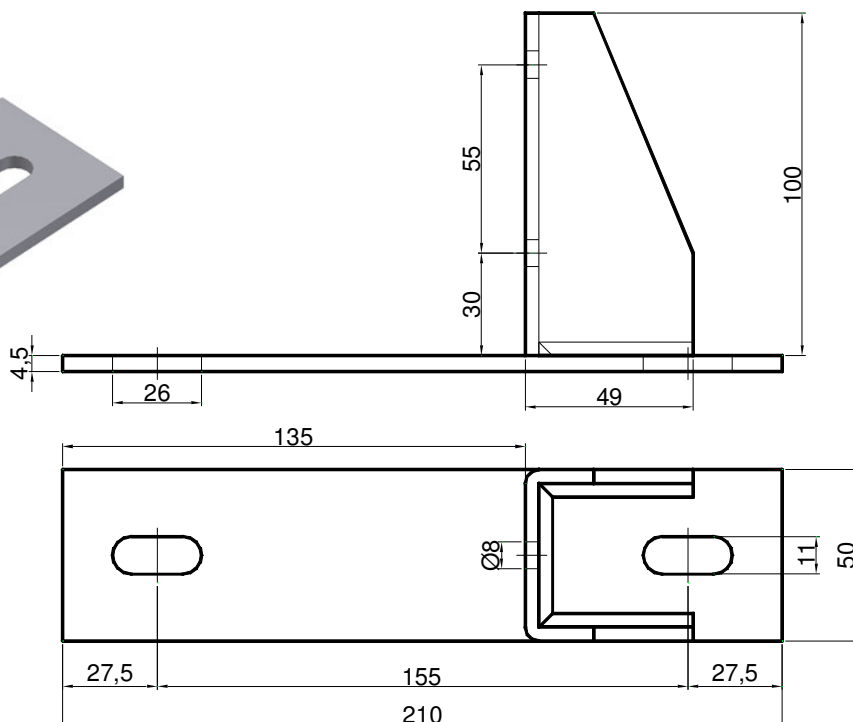
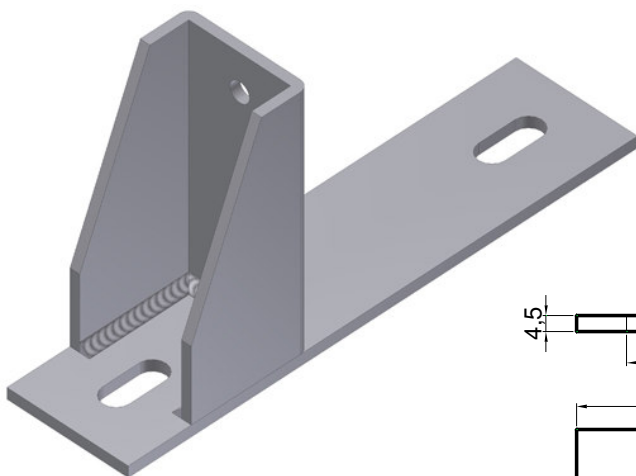

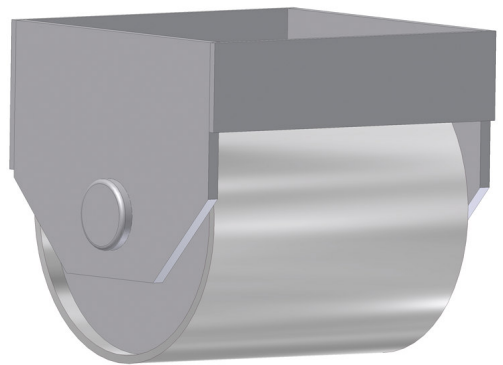
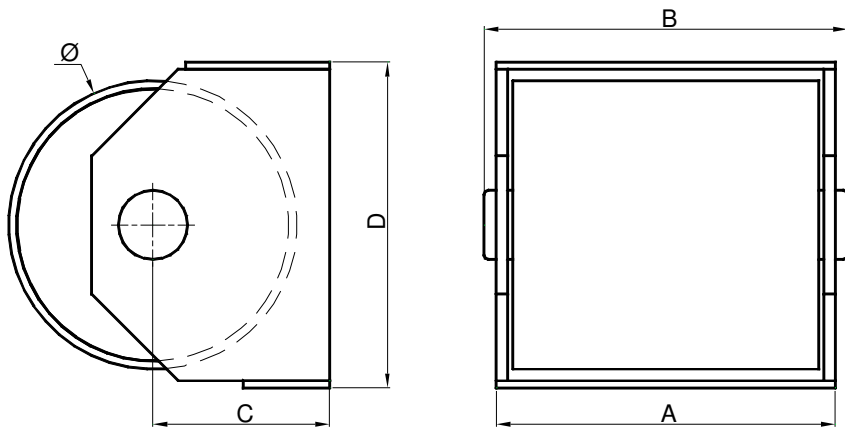

Articolo Code	Ø	A	B	C	D	Peso Weight kg
51000153	159	191	210	90	180	10,500
51000154	200	235	252	122,5	226	17,500

* Capacità 15 Ton. cad. per entrambe i modelli, per cassoni con volume da 7 a 35 m³.

* Capacity 15 Tons. each one for both types, for dump boxis with capacity from 7 to 35 m³.

Perno a bandiera

Pin to flag

Art. 45905250 - 1,550 kg

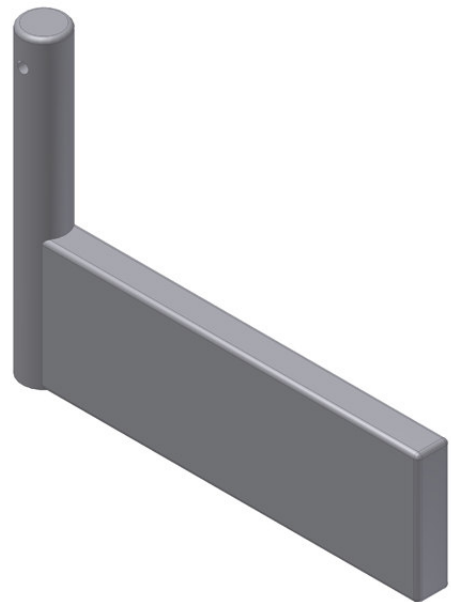
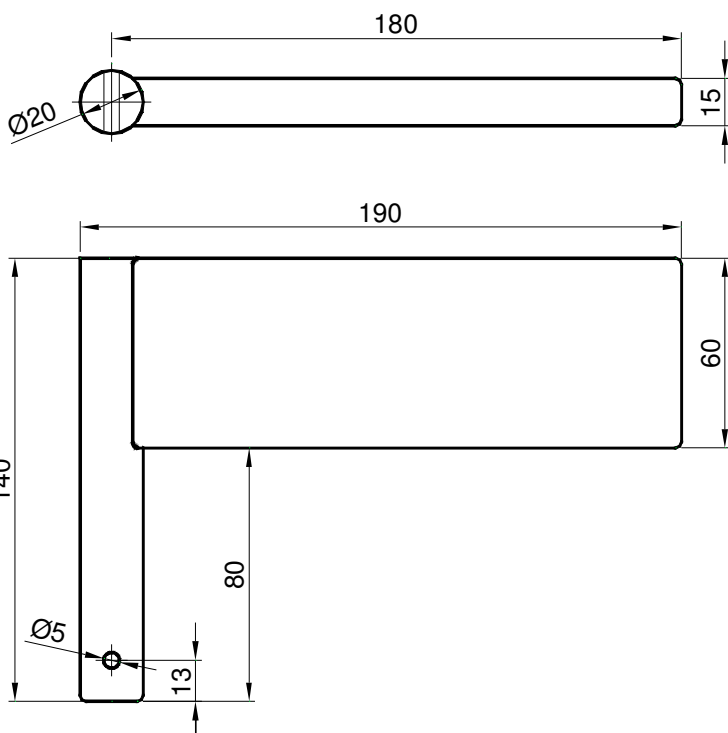

Fermabadile zincato
Galvanized stopper shovel
Art. 450080110 - 0,150 kg

